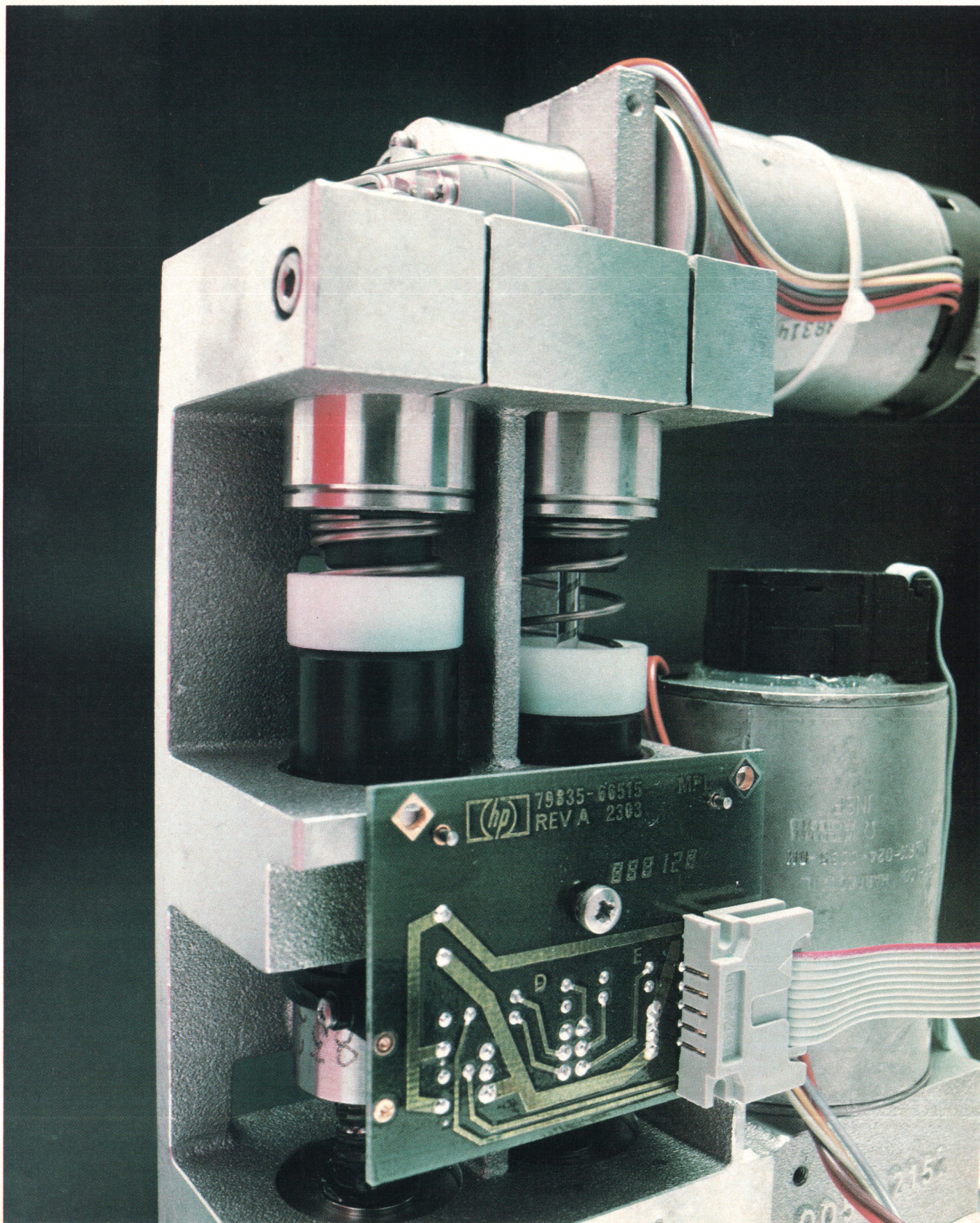


HEWLETT-PACKARD JOURNAL

APRIL 1984



HEWLETT-PACKARD JOURNAL

Technical Information from the Laboratories of Hewlett-Packard Company

APRIL 1984 Volume 35 • Number 4

Contents:

- 3 Low-Dispersion Liquid Chromatography**, by Robert J. Jonker and Gerard P. Rozing *New concepts and advanced design give better results faster, using smaller column volumes.*
- 7 Identification and Quantitation of PTH Amino Acids**, by Bernd Glatz and Rainer Schuster *The HP 1090 represents a major step forward in the analysis of these compounds.*
- 8 Design of the HP 1090 Control System**, by Herbert Wiederoder, Roland Martin, and Juergen Ziegler *It's a hierarchical structure with an HP personal computer in command.*
- 13 A New Solvent Delivery System**, by Wolfgang Geiger and Heinrich Völlmer *Precision pumps and an advanced control system deliver accurate flow rates over a 5000:1 range.*
- 21 Automatic Liquid Chromatograph Injection and Sampling**, by Wolfgang Kretz and Hans-Georg Härtl *Precise handling and injection provide high throughput and reduce costs.*
- 24 Mobile Phase Preheater Ensures Precise Control of LC Column Temperature**, by Helge Schrenker *Column temperature has become an important separation parameter.*
- 26 A Low-Cost LC Filterphotometric Detection System**, by Axel Wiese, Bernhard Dehmer, Thomas Dörr, and Günter Höschele *It offers more flexibility and better detectability and selectivity than others in its class.*
- 31 A High-Speed Spectrophotometric LC Detector**, by Joachim Leyrer, Günter E. Nill, Detlev Hadbawnik, Günter Höschele, and Joachim Dieckmann *It's designed for high-speed data acquisition and for qualitative and quantitative analyses using the latest columns.*
- 42 Authors**
- 44 New Technologies in the HP 1090 Liquid Chromatograph**, by Alfred Maute *Some of the new technologies aren't so new.*

In this Issue:



Not far from Germany's Black Forest is HP's Waldbronn Division. There, the research and development specialty is liquid chromatography, or LC, and the latest product offering is the HP 1090 Liquid Chromatograph, the subject of this issue. Coincidentally, in bringing the HP 1090 to life, it was to the watchmakers of the Black Forest and Switzerland that Waldbronn scientists turned for the skills to drill minute holes and cut tiny threads with high precision, and to shape and polish diminutive parts made of sapphire and similar materials. On page 44, Alfred Maute gives us his perspective on the remarkable engineering and manufacturing challenges that had to be met to make this new LC system a reality. In the article on page 3, two of the system's designers explain how new the HP 1090 is—different enough from previous LC systems to warrant the coining of the term "low-dispersion" liquid chromatography. Like the gas chromatographs we've featured several times in these pages, a liquid chromatograph is an instrument used for separating a sample of some compound into the components that make it up. The difference is that for GC the sample to be analyzed is a gas and for LC it's a liquid, perhaps sea water or a body fluid. The sample to be analyzed by LC is injected into a stream of solvent and carried through a tube called a column. The column is packed with particles of a porous material. The components of the sample reach the other end of the column at different times and are measured by a detector, which creates a peaked record of their passage. From the size and location of the peaks, it's possible to determine the concentrations of the various components. With additional information, it may be possible to identify the components of an unknown sample. The HP 1090 advances the state of this art by providing sharper, taller peaks in less time, using smaller samples and less solvent. Articles in this issue describe the sophisticated systems for control, solvent delivery, sample injection, detection, and data processing that make this performance possible. Our cover photo shows one of the metering pumps from the solvent delivery system. These pumps deliver flow rates from one microliter per minute to 5000 microliters per minute, smoothly and precisely. Few mechanical systems can match this 5000-to-1 range. For example, try to imagine the engine of your car running as smoothly at one revolution per minute as it does at five thousand. Mine won't run at all below about 1000.

One of the detector modules for the HP 1090, a high-speed spectrophotometric detector, is also available for use with other LC systems, regardless of who makes them. Called the HP 1040A, it's described in the article on page 31.

-R. P. Dolan

Editor, Richard P. Dolan • Associate Editor, Kenneth A. Shaw • Art Director, Photographer, Arvid A. Danielson • Illustrators, Nancy S. Vanderbloom, Susan E. Wright • Administrative Services, Typography, Anne S. LoPresti, Susan E. Wright • European Production Supervisor, Henk Van Lammeren

Low-Dispersion Liquid Chromatography

Low dispersion means it takes less sample, less solvent, and less time; it's a term coined by HP and implemented in a new high-performance LC system.

by Robert J. Jonker and Gerard P. Rozing

LIQUID CHROMATOGRAPHY is an analytical technique that gives qualitative and quantitative information about nonvolatile substances in mixtures. The variety of compounds that are now analyzed by liquid chromatography is enormous, ranging from substances containing only a few atoms to polymers having 100,000 or more, and from ionic to totally apolar substances. Liquid chromatography can be applied to samples where only a few microliters are available, which is the case in biomedical applications, or where a virtually unlimited sample is available, for example in the analysis of sea water.

The number of compounds in the sample may vary from only a few, such as in process control, up to several hundred in the analysis of body fluids. The ratio of concentrations of major to minor components can be up to one million or higher.

Information Processing in Liquid Chromatography

Fig. 1 shows the elements of a basic liquid chromatography (LC) system. A liquid sample is taken from a mixture to be analyzed and introduced to a part of the system that is at an elevated pressure. The sample is then transported to the separator by the flow in the system. In liquid chromatography the separator is called the column and consists in most cases of a tube filled with porous material called the stationary phase. A liquid, the mobile phase, flows through the tube between the particles of stationary phase material.

The components in the sample become distributed differently between the mobile and stationary phases, because they have different interactions (physical and/or chemical) with each phase. The nature and strength of the interactions can be selected by the choice of phases. This makes liquid chromatography the most versatile separation method known. As a result of the distribution, the components will move with different speeds through the column, so that

they will elute from it at different times. By changing the composition of the mobile phase during elution (gradient analysis) it is possible to analyze a wider variety of compounds in a given time than would be possible under constant conditions.

After the separator, the column effluent enters the detector, which measures a physical or chemical property of each now relatively pure compound. With the aid of *a priori* knowledge about the way the system responds to the components in the mixture (calibration), the detector response is transformed into the data of interest, that is, the nature and quantity of all relevant compounds in the mixture.

Dispersion During Separation

At injection, the solutes in the mixture are concentrated in space. During the separation process, the zone occupied by any given component is inevitably broadened, that is, the components become diluted by the mobile phase (Fig. 2). This process reduces the separation induced by the differing migration rates of the components and also hampers detection.

Lack of lateral equilibrium is the main source of broadening of the zone occupied by a component as it elutes down the column. The most important mechanism by which lateral mass transfer occurs is diffusion of the sample components within the flowing mobile phase and the particles of the stationary bed. This diffusion process would reach equilibrium after an infinitely long time. However, the residence time of a volume element of mobile phase at any location in the column is limited, so only a certain degree of equilibrium can be reached. For this reason, at the front of the zone, the concentration of a sample component in the mobile phase is slightly higher than the equilibrium value, while at the back of the zone the concentration in the stationary phase is slightly higher (Fig. 2). As a result,

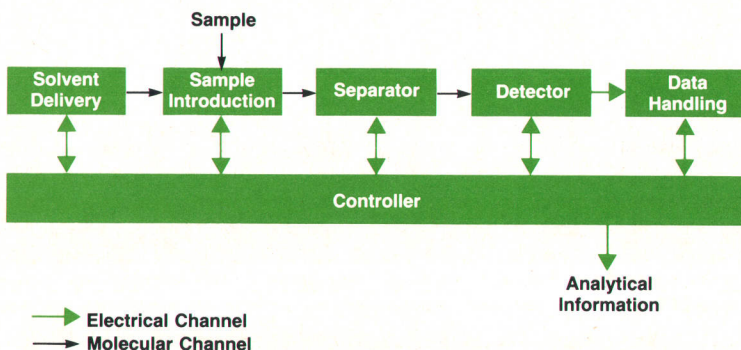


Fig. 1. A liquid chromatograph separates a sample liquid into its components. The separator, or column, is a tube filled with particles of a porous material.

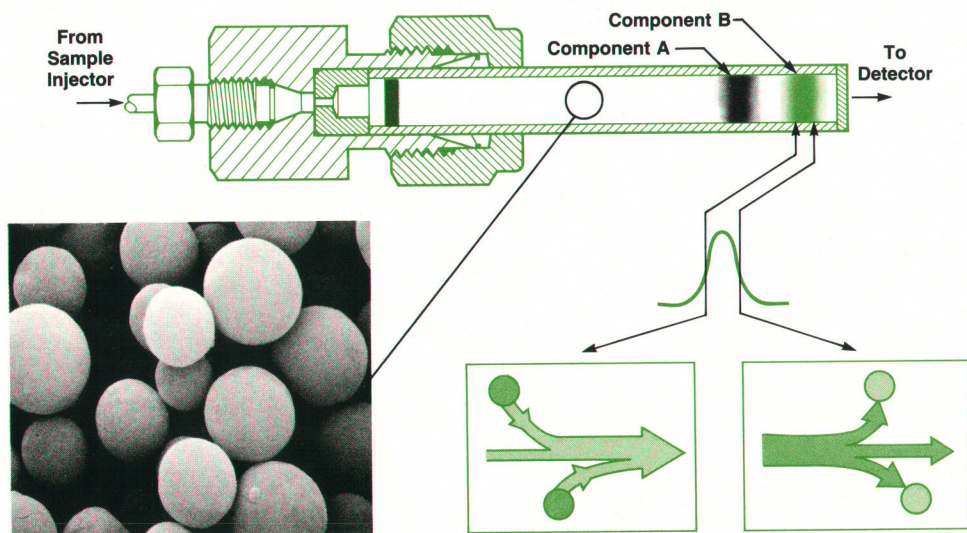


Fig. 2. The zone occupied by a sample component broadens as it elutes down the column. This is called dispersion. At the leading edge of the zone, the component's concentration in the mobile phase (solvent) tends to be higher than its equilibrium value (the value after an infinitely long time), and at the trailing edge the concentration in the stationary phase (particles) tends to be higher than the equilibrium value. Thus the leading edge travels faster than the average, the trailing edge travels slower, and the zone broadens. (Of course, the concentration is highest in the middle of the zone—much higher than the equilibrium value.)

the front moves faster than the average velocity of the component's zone and the back moves slower, making the zone broaden as it moves down the column.

The smaller the distance over which the diffusion has to take place, the shorter the time needed to reach a certain degree of equilibrium and the faster a separation can be obtained. The characteristic distance for this process is the particle diameter.

Halving the particle diameter allows doubling of the mobile phase velocity. These smaller particles give the same separation power in half the column length, so analysis time is quartered if particle size is halved. Fig. 3 shows a 91% reduction in analysis time when particle size is reduced by 70%. However, smaller particles show a greater resistance to flow, so higher pressure is needed to pump the mobile phase through the column.

Today's columns are packed with porous silica particles of 10, 5, or 3 μm diameter. The particles are porous, that is, 60-70% of their volume is empty. Typical particles have

pore diameters of 6 to 30 nm and internal areas of 150 to 400 m^2/gram . The silica is chemically modified at its surface, so that surface polarity can range from ionic to apolar to accommodate compounds of widely differing polarities. Major emphasis is on the silicas that are apolar after modification (reversed phase). These are suitable for analyzing polar substances.

The amount of mobile phase needed for an analysis is directly proportional to the volume of the column. Reduction of column volume is of importance because it reduces the volume needed for an analysis (solvents suited for liquid chromatography are expensive). Also, if only a limited amount of sample is available, the dilution of the sample in a low-volume column will be less, thereby improving detectability.

As mentioned above, one way that column volume has been reduced is by using smaller particles and shortening the column. Another way to reduce column volume is by reducing the diameter of the column. Whereas in the past

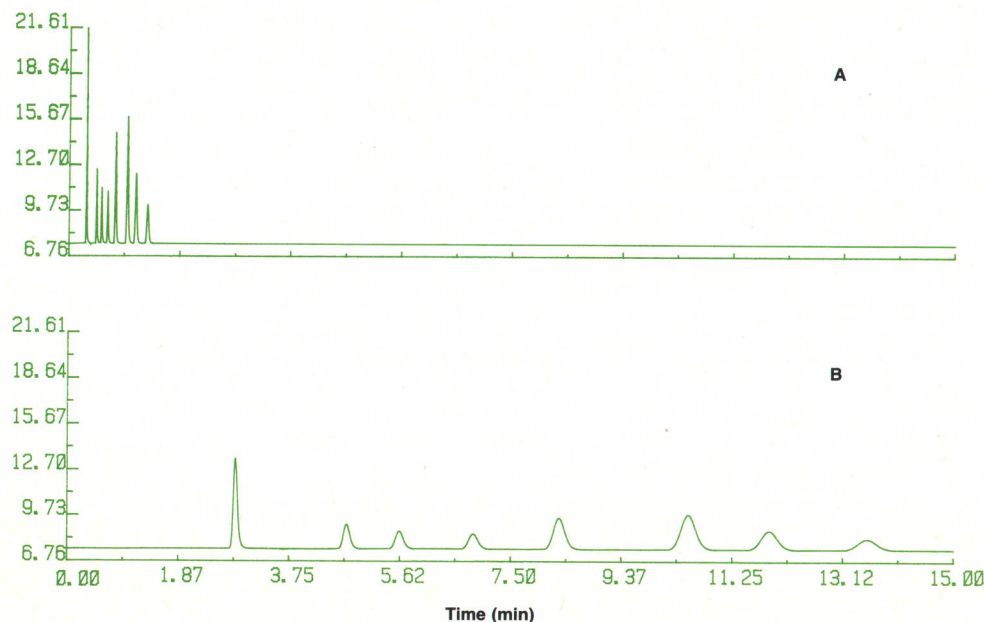


Fig. 3. These chromatograms show the influence of particle size on analysis time, solvent consumption, and detectability. 1 μl of a mixture of phenols was injected onto both columns, which had the same separation power ($N=7000$ plates). Column A: 60 \times 4.6 mm, 3- μm ODS Hypersil particles, flow rate 2 ml/min, total volume of mobile phase needed for an analysis = 3.0 ml. Column B: 200 \times 4.6 mm, 10- μm ODS Hypersil particles, flow rate 0.7 ml/min, total volume of mobile phase needed for an analysis = 10.5 ml. In both cases the mobile phase was 50% water and 50% acetonitrile, and the temperature was 40°C.

column diameter was 4.6 mm, it is now possible to use 2.1-mm columns, thereby reducing solvent consumption by a factor of five (see Fig. 4).

Instrumental Demands

The use of small-bore columns packed with small particles means that the analytes eluting from the column are less dispersed in time and volume. To maintain the separation obtained by the column, the dispersion in the non-column part of the system must be negligible compared to the dispersion in the column. This has a large impact on the design of the liquid chromatographic system—it has to be minimally dispersive.

The injection volume, the transportation of the analytes to the column and the detector, the time in the detector, and the time constants of the electronics (analog as well as digital) all disperse the chromatographic zones in volume and time. These dispersion processes can be limited by reducing the volume and optimizing the geometry of the noncolumn parts of the system, and at the same time optimizing the electronic time constants. The detector volume cannot be reduced indefinitely because a photometer needs a certain optical path length and reduction of the cross section of the cell reduces the amount of light through the cell. Lower light throughput means higher noise, limiting the dynamic range of the detector. By a proper design of the cell, however, detector dynamics can be preserved even with a low cell volume, maintaining important features such as multiwavelength detection. Dispersion in the connecting capillaries can be reduced by decreasing the internal diameter. However, this has to be traded off against the resulting higher pressure drop and a higher probability of clogging.

The flow rates required for the new low-dispersion columns are smaller than those used before, while the pressure at which this flow has to be delivered is greater. However, it is important not to lose the potential for gradient analysis and the use of conventional columns in the same system.

The result is that a dynamic range of 1 $\mu\text{l}/\text{min}$ to 5000 $\mu\text{l}/\text{min}$ is required of the solvent delivery system. The injection volume is dependent on the column and the method used. To maintain flexibility in this respect, injection volumes between 0.1 and 250 μl must be possible.

Often large quantities of samples have to be analyzed and automation of all steps of the analysis is a prerequisite. This can be done by using an autosampler and adequate communication between all subsystems.

Retardation of the solutes in the column is largely influenced by the temperature in the column. To assure reproducibility of both quantitative and qualitative data, the column has to be thermostatically controlled.

If all of these demands are fulfilled, we can say we have a system suited for low-dispersion liquid chromatography, a term coined by HP. Low-dispersion liquid chromatography means that chromatography is carried out more economically with respect to sample, solvent, and time.

New Low-Dispersion LC System

The new HP 1090 Liquid Chromatograph (Fig. 5), a family of integrated LC modules, represents a new concept in LC instrumentation. This low-dispersion LC system makes contributions in four areas of importance to the chemist:

- A growing family of integrated modules that combine the automation and communication capabilities of an integrated system with the operational flexibility and upgradability of stand-alone components
- A solvent delivery system with a dynamic range of 5000:1 that provides equally high precision when exploring new LC techniques or when using conventional methods
- Optimum chromatographic performance with standard columns, high-speed columns, and microbore columns, owing to minimized extracolumn peak broadening
- Microprocessors in each module, permitting intelligent communication with the system and providing fully synchronized automation.

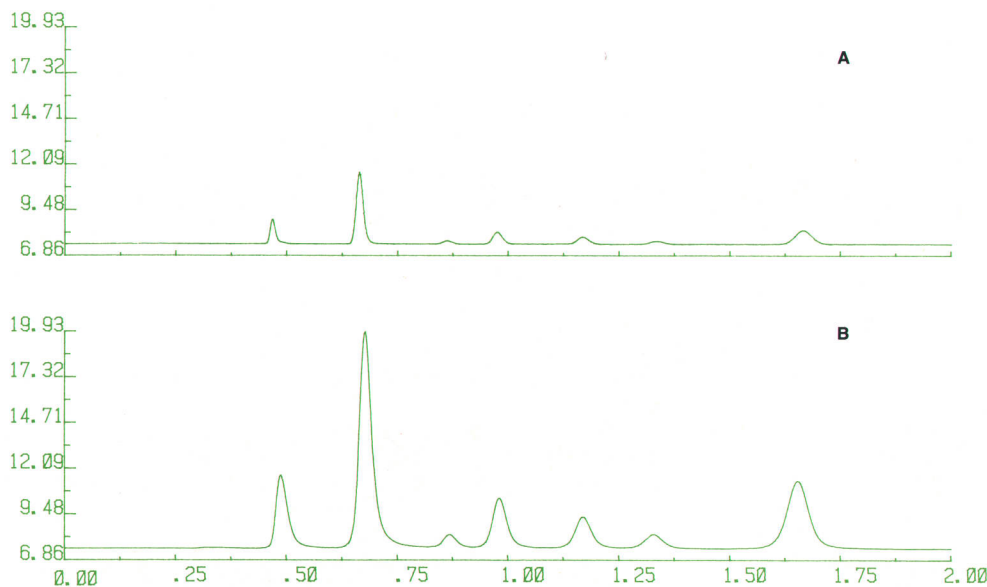


Fig. 4. These chromatograms show the influence of column diameter on solvent consumption and detectability. 1 μl of a mixture of benzene derivatives was injected onto both columns, which had the same separation power ($N=7000$ plates). Column A: 100 \times 4.6 mm, 5- μm ODS Hypersil particles, flow rate 2.35 ml/min, total volume of mobile phase needed for an analysis = 4.7 ml. Column B: 100 \times 2.1 mm, 5- μm ODS Hypersil particles, flow rate = 0.5 ml/min, total volume of mobile phase needed for an analysis = 1.0 ml. In both cases the mobile phase was 50% water and 50% acetonitrile, and the temperature was 60°C.

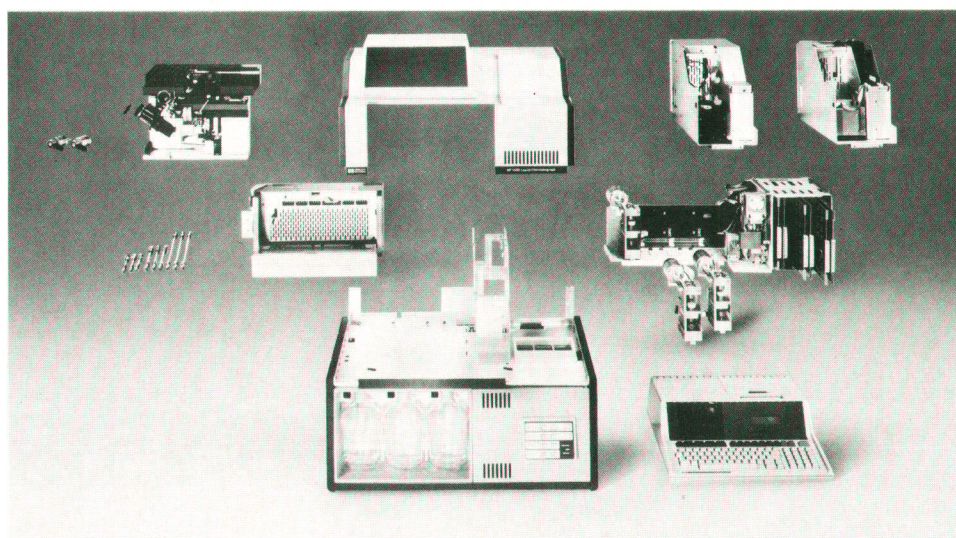


Fig. 5. The new HP Model 1090 Liquid Chromatograph is a family of integrated LC modules designed for low-dispersion LC. It is compatible with standard columns and methods or with the newer microbore and high-speed columns.

Chromatographic Aims

HP chemists believe that the need to improve laboratory productivity is leading to the adoption of two new column standards, using microbore and high-speed columns.

Compared to standard 10-cm columns packed with 5- μm particles, the new 6-cm \times 4.6-mm high-speed columns packed with 3- μm particles complete the analysis three times faster and improve detectability. The new 2.1-mm microbore columns reduce solvent consumption by 80% and increase column detectability five times. Both new columns maintain equivalent resolution.

With the HP 1090, the analyst can use the high-speed and microbore columns without sacrificing available resolution. All the individual parts of the HP 1090 are designed with minimum volume and optimum geometry to reduce external contributions to peak volume.

The new solvent delivery system generates gradients at high flow rates (for high-speed columns) or low flow rates (for microbore columns) with equal precision.

Integrated Modules for Maximum Operational Flexibility

Contained within the HP 1090 mainframe are component modules designed to perform as one integrated system. The chemist configures the HP 1090 for a particular type of application. Each module can be easily removed and exchanged.

Available are the following modules:

- DR5 solvent delivery system module. A dual-syringe metering pump in each solvent channel delivers any flow rate from 1 $\mu\text{l}/\text{min}$ to 5 ml/min by true volumetric displacement. This permits 1-99% gradients with better than 1% precision, even at 100 $\mu\text{l}/\text{min}$. Delay volume is below 0.5 ml. Performance at this level is essential if both high-speed and microbore columns are to be accommodated. Low-pressure metering and a high-pressure diaphragm pump ensure that solvent delivery is completely independent of solvent compressibility. Conversion from isocratic to binary or ternary (two or three different solvents) is a simple matter of adding one or two metering pumps and their circuit boards.
- Sampling modules. These can be completely automatic

or manual. The autoinjector uses one of two high-resolution syringes to deliver programmable injection volumes from only 0.1 μl up to 250 μl . For maximum throughput, the autoinjector can be combined with an autosampler. Ten interchangeable magazines simplify sample preparation, storage, and installation. The autosampler is fully programmable, giving fast, random access to 100 samples. The sampling time is compatible with high-speed LC.

- Detection modules. A choice of UV/Vis detection modules offers either fast, economical wavelength switching or instant spectral scanning. The filterphotometric detector has a filter wheel holding seven filters and is able to give programmable wavelength changes in less than two seconds, without baseline offset. All wavelengths are observed simultaneously by the diode array detector, allowing eight wavelength signals, each of any bandwidth, to be monitored in each analysis. The instantaneous acquisition of spectra, automatically or on demand, gives comprehensive information on component identity and purity.
 - Column compartment. The HP 1090's column compartment ensures temperature homogeneity within the column by means of an airbath thermostat and by preheating solvent in a 2- μl capillary. The heat exchanger maintains a temperature precision of $\pm 0.5^\circ\text{C}$.
 - A wide variety of data-handling and communication options are accommodated through analog output, HP-IB (IEEE 488), or serial interfaces. The system master is the HP-85 Personal Computer. As new communication standards become established, they can be incorporated into the existing architecture.
- The benefits resulting from these features are:
- The ability to explore new LC techniques without losing the flexibility to run routine methods
 - Increased throughput, by combining high-speed columns, fast sampling, and intelligent automation
 - Increased detectability and an 80% reduction in solvent consumption through the use of microbore columns
 - Fully synchronized operation and complete documentation

(continued on page 8)

Identification and Quantitation of PTH Amino Acids

by Bernd Glatz and Rainer Schuster

In biochemical research the determination of primary structures of proteins or polypeptides has been of great interest for about 25 years. The knowledge of the structure of these macromolecules gives a better understanding of their function in plants, animals, and human beings and makes it possible to synthesize compounds of interest.

Proteins and peptides consist of a large number of amino acids which are coupled by peptide bondings. If the kinds of amino acids and their sequence can be determined, then the primary structure is known. With a so-called Edman degradation, the peptide bonding of the final amino acid can be broken, converting this amino acid to its phenylthiohydantoin (PTH) derivative. This PTH amino acid can then be identified and quantitated by chromatography. In this way the kinds of amino acids and their sequence can be determined.

The structures of well known proteins like insulin, ribonuclease, and hemoglobin were elaborated with the Edman degradation 25 years ago. At this time, however, gram amounts of a protein were needed and the procedure was very time-consuming.

Today the structures of brain peptide hormones, membrane proteins, polypeptides involved in cell development, or proteins responsible for diseases are of great interest. Since these compounds are only available in milligram amounts, the sensitivity of the protein sequence analysis has had to be increased. The Edman degradation is now fully automated and the yield is significantly improved. The identification and quantitation of the PTH amino acids is commonly performed by high-performance liquid chromatography (HPLC). Today the limiting factor is the sensitivity of the HPLC system. To maximize the sensitivity of the HPLC system, the sample dilution should be as small as possible, and the detection device should be as sensitive as possible.

The HP 1090 makes three major contributions in terms of increased sensitivity:

- It can handle microbore columns. Compared to a standard 4.6-mm inside-diameter column, a 2.1-mm microbore column

exhibits five times lower dilution of a sample. Therefore, five times better detectability can be achieved.

- It offers sensitive detection modules. The filterphotometric and photodiode array detectors achieve noise levels of 10^{-4} A.U. (absorbance units) under optimized conditions, representing two of the most sensitive UV detectors available.
 - It offers optimum module compatibility. It is important to maintain the low noise of the detector, especially for trace analyses. Temperature fluctuations, pulsations and nonoptimal mixing characteristics of the solvent delivery system, electrical incompatibilities between modules, and other factors can deteriorate the detector's performance.
- To make it possible to operate microbore columns with adequate performance, the HP 1090 also provides:
- A solvent delivery system that can deliver low flow rates (100-300 $\mu\text{l}/\text{min}$) with high precision and full gradient capability from 1 to 99%
 - Small extracolumn volumes to maintain the resolution of the column
 - Small and reproducible injection volumes (1 to 5 μl).

These capabilities of the HP 1090 make it feasible to improve the sensitivity of existing methods by an order of magnitude.

The first step in the method development consists of the separation of standard PTH amino acids. Because there are 25 different PTH amino acids, and many of them show similar chromatographic behavior, the separation itself is a major challenge.

Fig. 1 shows a chromatogram with all 25 PTH amino acids, separated on a 100×2.1 -mm reversed-phase column. This separation involves a complex ternary gradient of A=0.01 molar sodium acetate (pH=5.8), B= methanol, and C= acetonitrile. To obtain reproducible results, the solvent delivery system must precisely deliver flow rates of 1.5 to 30 $\mu\text{l}/\text{min}$ from one channel.

From Fig. 2 the sensitivity of the method can be determined. Even as small a sample as 11.9 picomoles of each PTH amino

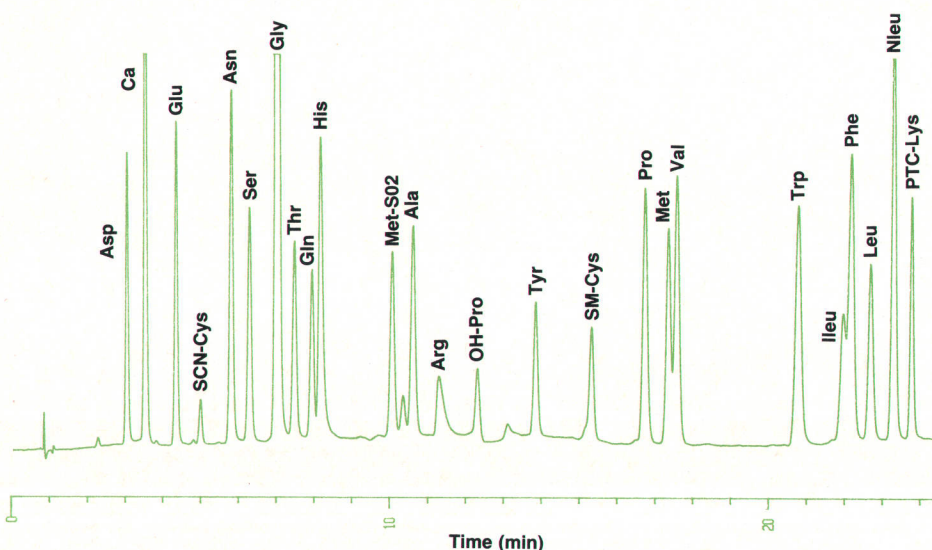


Fig. 1. An HP 1090 chromatogram showing all 25 PTH amino acids separated on a 100×2.1 -mm reversed-phase column.

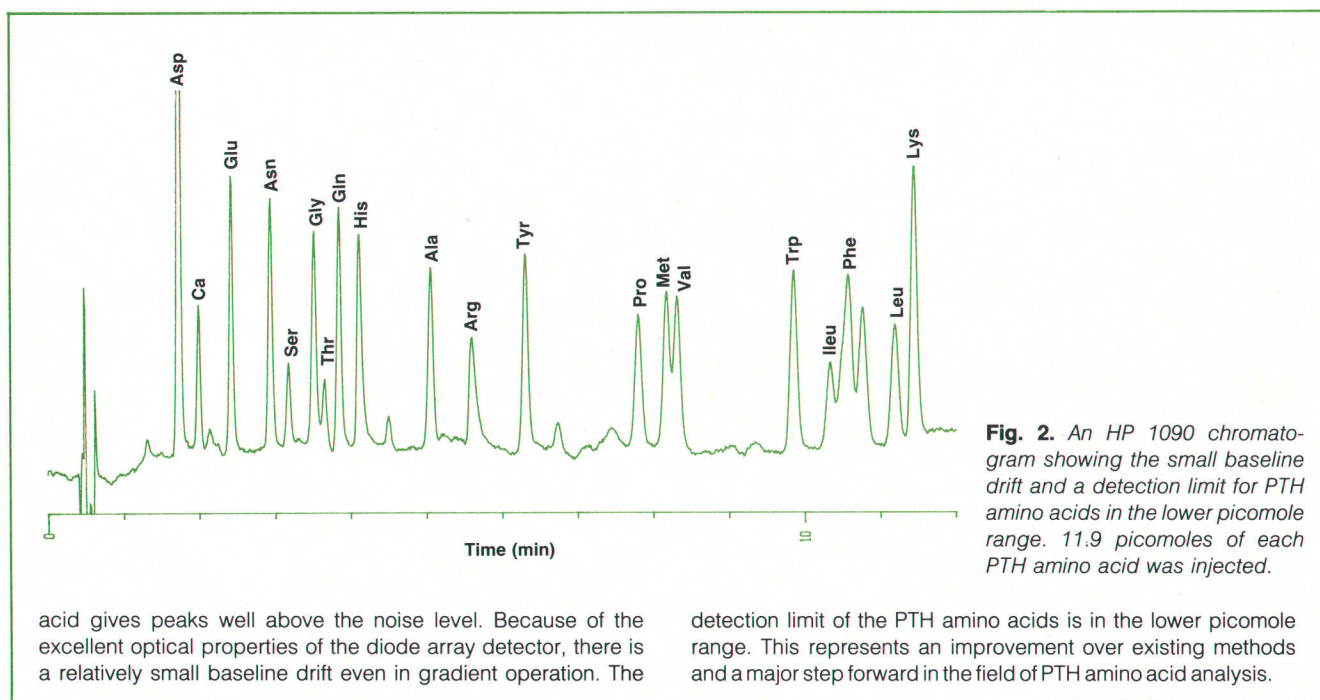


Fig. 2. An HP 1090 chromatogram showing the small baseline drift and a detection limit for PTH amino acids in the lower picomole range. 11.9 picomoles of each PTH amino acid was injected.

- An integrated system that can be adapted as technology advances and as the needs of the analyst change.

Acknowledgment

The authors wish to thank Henk Lauer of the HP Laboratories chemical systems department for his trendsetting research at the Waldbronn Division in the late 1970s, which formed the basis for low-dispersion LC.

Design of the HP 1090 Control System

by Herbert Wiederoder, Roland Martin, and Juergen Ziegler

STARTING FROM SCRATCH with a new liquid chromatograph concept is a challenge for each engineer in the lab. On one hand, there are complex mechanical components like the solvent delivery system, the column compartment, the injector system, the autosampler, and the detector. On the other hand, an intelligent control system is necessary to coordinate these various modules. To get a cost-effective, easily upgradable, and flexible system, some key objectives were decided upon:

- Distribute the functions of the system into hardware control, data acquisition, data processing, and a user interface.
- Use a hierarchical structure that is easily understandable.
- Use the HP-IB (IEEE 488) as the communication link to a standard low-cost HP personal computer, the HP-85.
- Use the personal computer as the user interface, as the coordinator for multiple analysis processes, and for data evaluation.

System Overview

Fig. 1 shows the general architecture of the HP 1090 LC System. It is a typical hierarchical structure with the HP-85 as the head. The HP-85 serves two purposes: the human interface and the management of automatic multiple analyses with variable parameters. The actual analysis is done by two HP-IB devices, the liquid chromatograph (LC) and the diode array detector (DAD). Each HP-IB device has its own clock. Because the injector determines the beginning of the analysis, a synchronization mechanism has been established between the LC and the DAD and other devices. Accurate analysis requires synchronization within less than 70 ms. This is done by frequently setting the LC and DAD clocks and sending the injection time to the DAD once the injector completes the injection.

A lower-cost filterphotometric UV detector (FPD) is interchangeable with the DAD. This detector, the LC, the DAD, the other modules within the mainframe, and the HP-85 software are described in other articles in this issue.

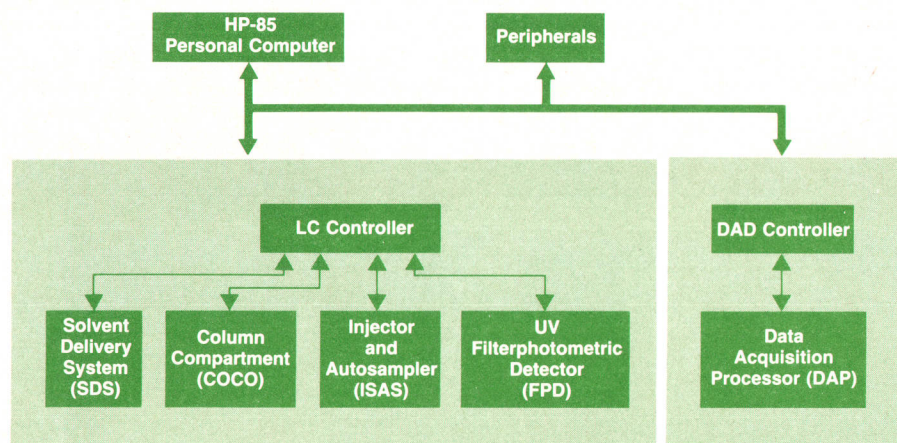


Fig. 1. The architecture of the HP 1090 LC System is hierarchical with the HP-85 Personal Computer at the head. The HP-85 manages multiple analyses and serves as the human interface.

System Communication

The distribution of the HP 1090 System into modules is done on three levels (Fig. 2). Level 1 can be seen by the user. It is represented by the physical devices, like the HP-85 or the plotter, and is connected via the HP-IB. The LC mainframe itself is distributed into two addressable HP-IB devices, the LC controller and the DAD controller.

Level 2 is created by the hardware design of the LC devices, which is based on several single-processor computers located on different boards inside the mainframe and connected by special hardware.

Level 3 is implemented by software within a single-processor computer. The applications software is based on a multitasking operating system. It is designed as a collection of tasks, each performing a particular function and interacting through a communications mechanism.

The different components at any distribution level within the system are relatively independent. Each level can be characterized by the usable resources for coupling the components. For level 1 it is the message communication over the HP-IB by cables and standard hardware interfaces. Transmission control is restricted to some standardized methods. The level 2 environment consists of hardware designed specifically for liquid chromatography. It uses an interprocessor link implemented by shared memory or I/O ports and interrupt lines. The coupling of components at level 3 is done by the operating system, which provides an intertask communications mechanism.

Communication is not only required between the components of a certain level, but also from one level to another. The 1090 uses an intertask and interprocessor communications mechanism that resembles a message system. The message is packed into a memory buffer called mail and sent to a specified mailbox. A task waits for mail at a mailbox, receives it, and processes the message data. Mail routes can be established by a sequential list of receivers stored in the mail itself.

A message from an outside HP-IB device has to be transformed into mail and sent to its receivers. The operating system creates a quasiparallel, multibyte communication with multiple data paths. The HP-IB supports only a single byte-serial data path without parallelism. The solution for this conflict is time multiplexing of messages from different data paths. A part of the operating system called the HP-IB transformer provides a mechanism that allows the HP-IB

controller to arbitrate between concurrent communication requests according to any priority strategy.

The HP-IB transformer amounts to a set of connectors for data paths, called communication units (CUs). Fig. 3 shows a block diagram of this design. To the application software, a CU looks like a mailbox. To the HP-IB controller, a CU looks like a subdevice, which is selected by a secondary command as defined in the HP-IB standard.

The LC Controller

The separation part of a liquid chromatograph consists of the solvent delivery system (SDS), the column compartment with heated oven (COCO), and the injector system and autosampler (ISAS). Fig. 4 is a block diagram of the 1090 LC showing how these modules and the UV filterphotometric detector (FPD) are connected to the LC controller.

The master controller is a Z80A-based microcomputer with 48K bytes of program memory on the board, 4K bytes of program memory on the HP-IB interface, and 8K bytes of data memory. The rest of the 64K linear Z80A address space is used for memory-mapped I/O to the external blocks via the internal/external bus. Six interrupt sources are con-

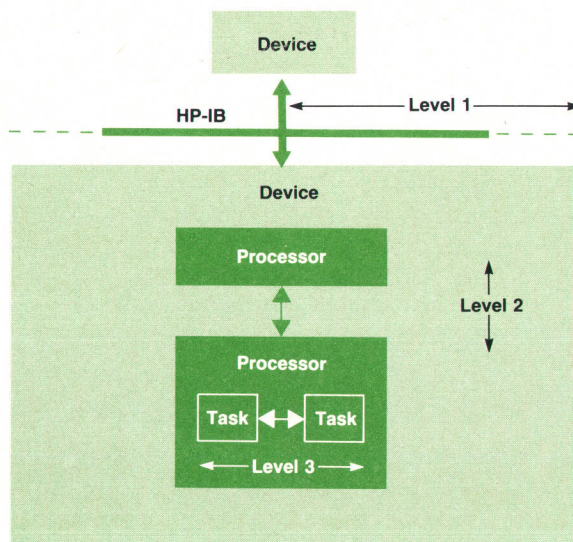
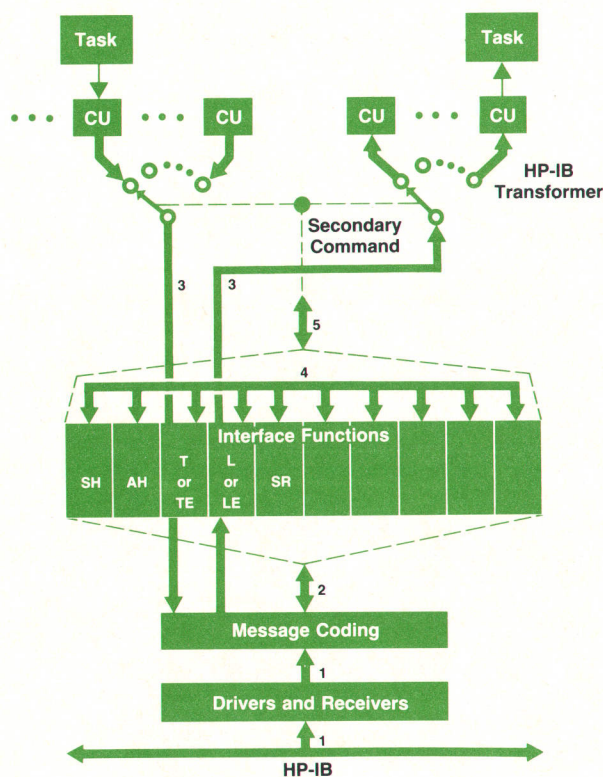


Fig. 2. Communication in the HP 1090 LC System takes place on three levels.



1. Interface bus signal lines
2. Remote interface messages to and from interface functions
3. Device-dependent messages to and from device functions
4. State linkages between interface functions
5. Local messages between device functions and interface functions

Fig. 3. A part of the 1090 operating system called the HP-IB transformer allows the HP-IB controller to arbitrate between concurrent communication requests. It amounts to a set of connectors for data paths called communication units (CUs).

nected to priority logic (no nested interrupts). Four channels of a Z80A CTC (counter timer circuit) chip are used as a time base and for the analog-to-digital converter. This A-to-D converter (Fig. 5) is an integrating voltage-to-frequency converter. The frequency is measured with two channels of the CTC. The frequency range is switchable to provide either 8-bit resolution or 10-bit resolution. Because the CTC has only 8-bit counters, overflow interrupts are counted by the software for 10-bit resolution. Using the CTC for analog-to-digital conversion makes it easy to synchronize the measurements with the high-pressure pump and to interface the pump to the Z80A.

The column compartment contains an oven, which can be heated up to 100°C and has a temperature stability of $\pm 0.5^\circ\text{C}$.

The miscellaneous I/O port on the LC controller board (Fig. 4) is used for remote control and to turn off the main power supply for automatically going to a standby mode. The remote control lines can be used for synchronization of external instruments (e.g., an integrator).

The purpose of the local keyboard is to turn on and off the main power supply (operate/standby mode), the SDS, and the FPD or DAD. It also allows local starting and stop-

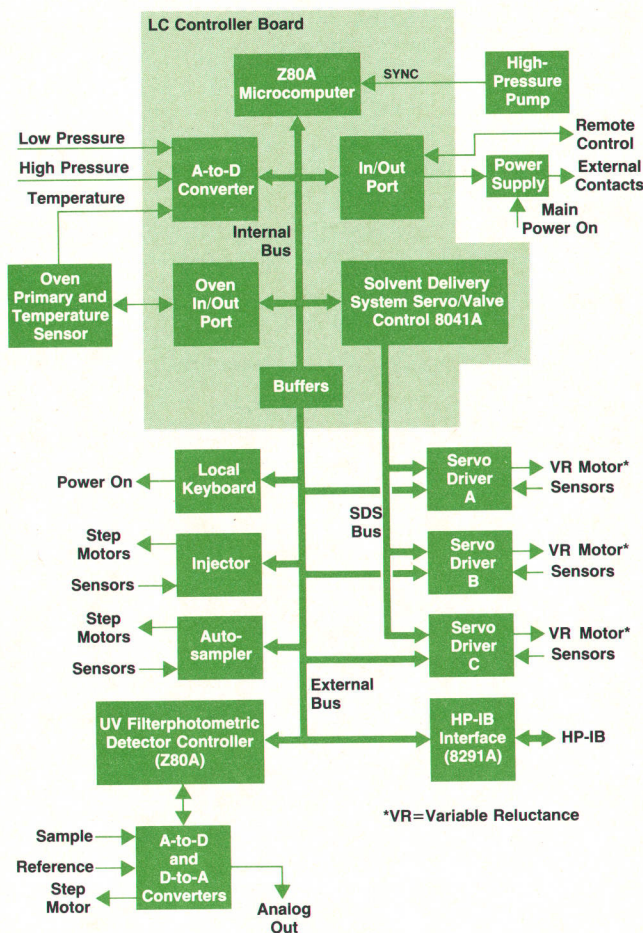


Fig. 4. Block diagram of the HP 1090 control system.

ping of an analysis and displays the instrument status. The injector and autosampler (ISAS) drivers are identical boards. Each board serves as a power driver for two step motors and two pneumatic actuators. The step motors are directly controlled by the Z80A. Five light sensors are interfaced to the Z80A to provide status information for controlling the ISAS.

The data acquisition processor (another Z80A) of the FPD is directly connected to the LC controller via the external bus. Using the LC controller capability provides a cost-effective solution for integrating the detector into the system. Messages between the FPD and the LC controller are sent by interrupt-driven one-way communication in which the FPD is the slave.

External communication to the HP-85 is via the HP-IB. This is done by the HP-IB interface board, based on an 8291A Talker/Listener with a 4K-byte program memory.

To achieve a dynamic range of 5000:1 in the SDS, the metering pump servo circuit gets a new position every $t_u = 1.2$ ms for precise continuous motion. This is done with one 8041A single-chip microcomputer. The master Z80A calculates the incremental step N , sends it to the 8041A, and controls the status of the SDS. The incremental steps are calculated by the following formula:

$$N = K \frac{dv}{dt} t_u,$$

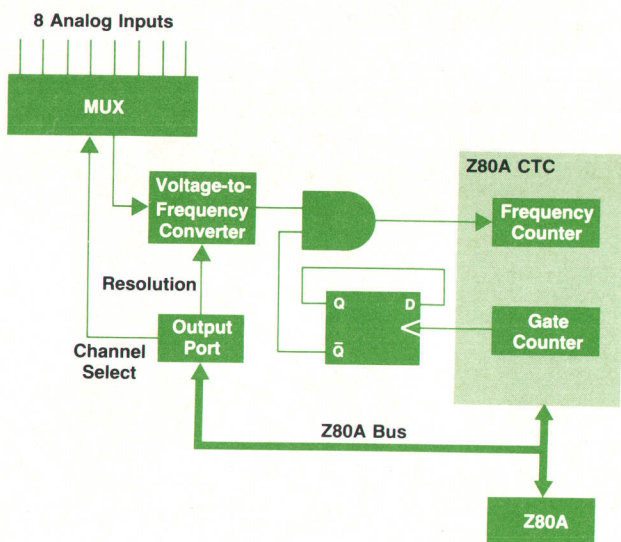


Fig. 5. This analog-to-digital converter implemented with part of a Z80A counter timer circuit is used to measure various pressures and temperatures.

where N = step size,
 K = constant = $2.5/\mu\text{l}$
 dv/dt = flow rate = 0 to 5000 $\mu\text{l}/\text{min}$
 and t_u = update time in seconds.

The 8041A calculates the new servo positions for all three solvent channels with an integrating rounding algorithm.

LC Controller Software

The software resides in 52K bytes of read-only memory, which includes the HP-IB transformer. The software structure is based on the multitasking operating system and the communications mechanism mentioned earlier. Each module represents an independent process and owns a task. Additional tasks are required for instruction decoding, the HP-IB transformer, the time program, parameter listing, and system coordination. Fig. 6 shows the tasks and their main internal data paths. All the tasks receive their instructions from the instruction decoder, the system coordinator, or the time program. The instruction decoder checks the received instructions from the HP-IB transformer. If the syntax is correct the instruction is converted to an internal format for the various tasks. The instruction reply and the execution are done by the individual task.

The system is interrupt-driven and requires an operating system overhead of less than 1.5 ms to achieve a time resolution in the Z80A of 5 ms.

The Z80A software sends a periodic message to the 8041A slave processor, which sends a trigger signal to a watchdog circuit. This circuit generates a "system OK" message to the various modules. This is for fault monitoring of the software to keep the hardware modules in a safe status.

The software provides all of the LC functions for the complex mechanical system within the mainframe. Time-

critical functions are implemented relatively close to the hardware. The HP-85 would have been overloaded if it had to execute such functions. A single analysis is managed by the local controller with the HP-85 acting more as a terminal for entering and modifying parameters and for evaluating preprocessed data from the DAD. However, the sequence of a multiple analysis is managed by the HP-85.

Diode Array Detector Controller

The controller built into the diode array detector is one of the major subsystems in the 1090 multiprocessor control system. It consists of two processors, the data acquisition processor (DAP) and the communication processor (COM).

A significant part of the software of the HP-85 is related to the diode array detector. Fig. 7 shows the hardware block diagram.

The purposes of the DAD controller are to:

- Control, calibrate, and test the detector hardware
- Acquire light measurements from the flow cell via the photodiode array, the readout electronics, and the analog-to-digital converter at a rate of 22,500 readings per second
- Preprocess the light measurements into absorbance data
- Reduce the huge amount of measurements to a reasonable amount of information
- Format and buffer this information so that it can be used efficiently by the HP-85.

Fig. 8 shows the main streams of information through the two processors. For simplicity, all control and status data paths have been omitted from this picture.

The data acquisition processor (DAP) takes care of all

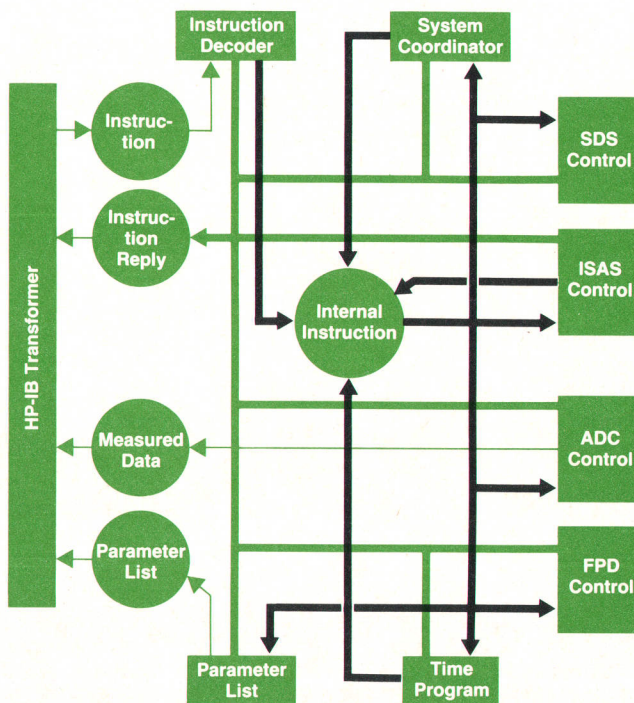


Fig. 6. The HP 1090 software structure is based on a multitasking operating system. Each module owns a task, and there are other tasks for various functions. Shown here are the tasks and the main data paths.

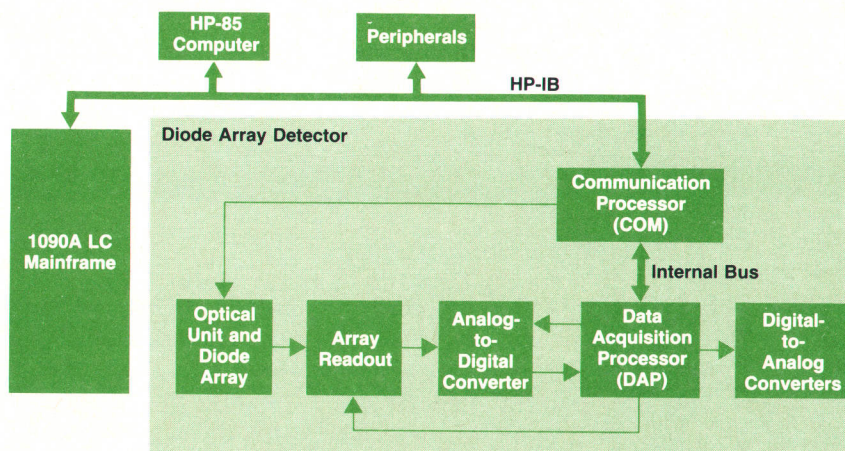


Fig. 7. Hardware block diagram of the diode array detector controller.

high-speed interactions with the hardware. It reads the array and the analog-to-digital converter every 44 microseconds. To serve the hardware properly, the DAP must react to external events within less than six microseconds. The rest of its time is spent in processing. It converts the primary data into absorbance data and generates three types of information:

- Spectra: absorbance as function of wavelength at a certain time. By averaging up to 255 measurement cycles of the array, the "exposure time" for the spectra can be matched to the speed of the separation, i.e., the width of the peaks eluting from the column.
- Signals: absorbance as a function of time at eight different wavelengths with variable bandwidth and response time.
- Analog outputs: two signals are converted to a voltage proportional to absorbance. Recorders or integrators can be connected to these outputs to obtain quantitative results.

The outputs from the DAP are transmitted to the COM via a shared RAM (a memory accessible from both processors) and an interrupt mechanism to alert the receiver when an interprocessor message comes in. The format of the interprocessor messages in the shared RAM is identical to the format for intertask communication (mail) within the processor. This minimizes the overhead involved in passing a piece of information from the DAP to any task within the COM. This is necessary because the COM needs to react to an incoming spectrum or signal message within less than five milliseconds.

The communication processor (COM) does further data reduction and formatting operations on signals and spectra to prepare them for their final use. Two classes of outputs are generated:

- Monitor data: signals and spectra at regular intervals for immediate display on the HP-85's CRT screen. This allows the user to see what is going on in the flow cell. The major concern for this data path is that the information be up to date.
- Raw data file: the user can specify which subset of all acquired signals and spectra are to be memorized in a raw data file together with all relevant acquisition parameters. A peak detection algorithm can be used to memorize only the most interesting spectra when a com-

pound is eluting from the column. This reduces the amount of data to be stored without losing important information.

The raw data file is a compact, well organized image of all relevant measurements during an analytical separation. It is used by post-run evaluation programs to draw graphic output. It can be stored for later comparison with results from other analyses.

Other tasks in the COM take care of transforming inter-

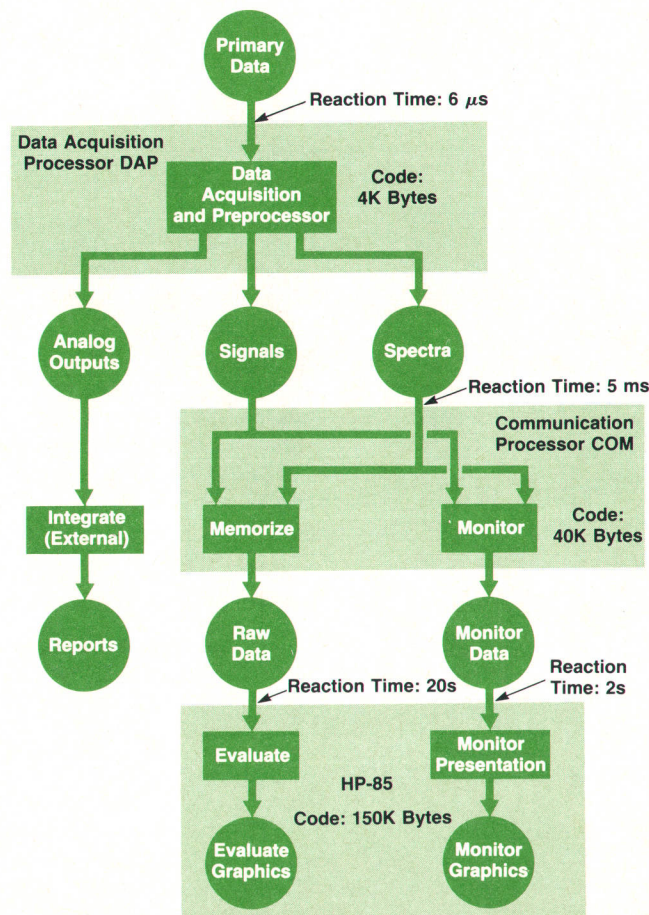


Fig. 8. Data flow in the diode array detector controller.

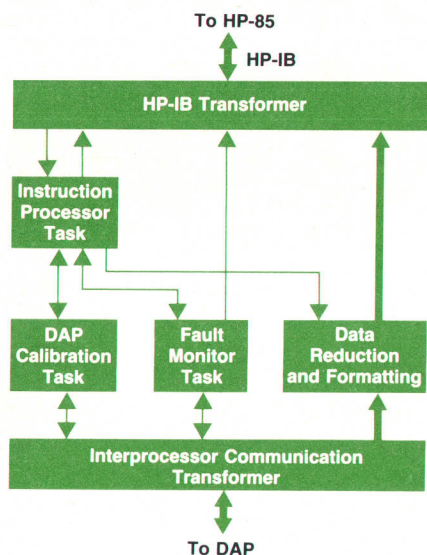


Fig. 9. Tasks and intertask communication in the COM processor.

task communications (mail) into interdevice HP-IB data messages, decoding and execution of instructions from the HP-85, calibration, fault monitoring, and control of slower

hardware. These tasks and the various data paths between them are shown in Fig. 9.

The COM communicates upward to the HP-85 via the HP-IB. The transformation of intertask communications into HP-IB data messages is quite simple. The bytes contained in the memory buffer for intertask mail are put one after another onto the HP-IB after the associated CU has been addressed. The HP-85's I/O ROM performs the inverse function. Thus, after a transmission is completed, a copy of the mail sent by a task in the COM is available in the HP-85. The COM provides buffering for raw data and monitor data to allow long reaction times for the HP-85. Therefore, the HP-85 can serve the diode array detector concurrently with other HP-IB devices (1090 LC mainframe, plotter, disc) by multiplexing the HP-IB.

Acknowledgments

Many people contributed to the design of the HP 1090 control system. We would like to acknowledge the engineers who contributed their skills and foresight to the development of the system: Hans-Joachim Buhl, Hans Biesel, Christian Buettner, Gerhard Plé, Joachim Dieckmann, Gerd Pfaffmann, Günter Hörschele, Helmuth Elgass, Reinhard Zinburg, and Art Schleifer. Bernd Glatz, Steve George, Johannes Krey, Charlie Euston, and many other marketing people also contributed to this project.

A New Solvent Delivery System

by Wolfgang Geiger and Heinrich Völlmer

IN A LIQUID CHROMATOGRAPH, the quality of the solvent delivery system determines the quality of the analytical results. If reproducible results are required, the solvent delivery pump must provide a flow stability better than 1% for all flow rates, gradients, solvents, and column backpressures.

Today's LC flow range is 1 to 4 ml/min. Tomorrow will see at least a tenfold increase in that dynamic range, mostly on the low end.

The 79835A Solvent Delivery System for the HP 1090 Liquid Chromatograph is based on the concept of physically separating the function of flow metering from that of

pressure generation. It delivers any flow rate from 1 μ l/min to 5000 μ l/min with better than 1% precision at 100 μ l/min or more. It can run 1% to 99% gradients and meter up to three solvents. It is designed for minimum pump response time and total delay volume.

Design Requirements

The main goals for the design of the solvent delivery system (SDS) were:

- Maximum performance at moderate cost
- Extremely wide flow and composition ranges to satisfy any customer

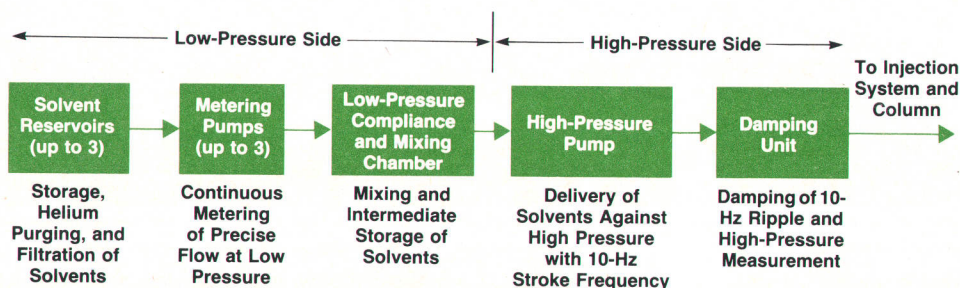


Fig. 1. Block diagram of the 79835A Solvent Delivery System (SDS), a module of the HP 1090 LC System.

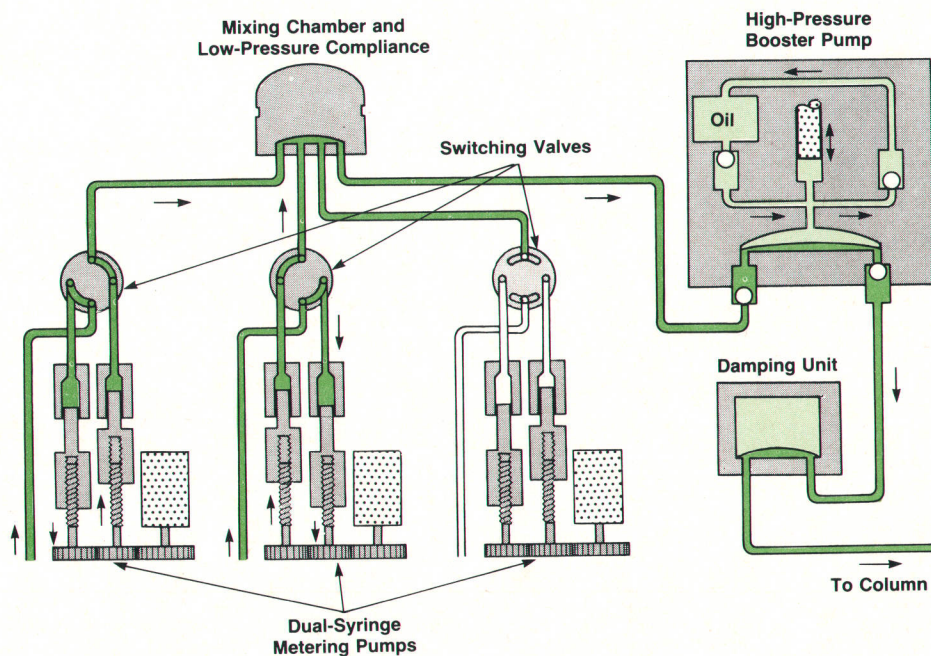


Fig. 2. Dual-syringe metering pumps deliver precise flow rates from 1 to 5000 microliters per minute. Metering is done at low pressure to avoid errors caused by solvent effects. A high-pressure booster pump delivers the solvent to the column.

- Modular design for serviceability
- Extensive testing and conservative design to ensure reliability
- Performance matched to state-of-the-art column technology, but not precluding the use of popular existing columns.

The last goal was of major importance. State-of-the-art columns have inside diameters of 1.0 and 2.1 mm. The I.D. of existing columns may be as large as 4.6 mm. Flow rates range from 25 to 250 $\mu\text{l}/\text{min}$ for 1.0-mm columns, from 100 to 1000 $\mu\text{l}/\text{min}$ for 2.1-mm columns, and from 500 to 5000 $\mu\text{l}/\text{min}$ for 4.6-mm columns. A high-performance system also has to offer gradient capabilities for all of these column types. This means solvent composition in the range of 1% to 99%. For the 79835A SDS, a flow rate range of 1 $\mu\text{l}/\text{min}$ to 5000 $\mu\text{l}/\text{min}$ was established. This wide range of flow rates has to be delivered precisely, with negligible influence from pressure and solvent properties.

Of various solvent properties, compressibility, viscosity, pH factors, and gas solubility are of particular interest in SDS design. Compressibility may cause reduced flow at higher pressures, an effect known as rolloff. Chromatographic solvents have different compressibilities which vary with temperature. In some cases, mixture effects make compressibility unpredictable.

Viscosity, along with I.D. and flow rate, determines the pressure drop in the system tubing. On the high-pressure side, there can be different pressures for different solvents or solvent compositions, even when the flow rate is the same. On the low-pressure side, higher-viscosity solvents need pressures farther below ambient to be sucked into the system.

Chromatographic solvents may have pH factors in the range of 2.3 to 9.5. This means that the number of materials available for use in the solvent path is drastically limited. Only a few plastics, gold, stainless steel, ceramic, ruby, and sapphire meet the requirements. Wear is also a major

consideration, since the system should not introduce particles into the solvent stream.

Gas solubility varies for different liquids and depends on temperature and pressure. If the pressure in the low-pressure side drops significantly below ambient when sucking in solvent, a gas bubble may be introduced into the pump system. This is unacceptable, since it can affect the performance drastically or cause an error condition.

SDS Design Concept

There is no device or method available to measure flow over a dynamic range of 1 to 5000 $\mu\text{l}/\text{min}$ at an acceptable price. This problem is further expanded by the solvent properties already discussed, so that it would require a complex nonlinear system to control flow in this range, even if it could be measured. The approach taken in the 79835A SDS is to meter the solvent instead of measuring flow rate. The design components are shown in Fig. 1.

Metering is done at low pressure, where solvent effects are negligible, by a specially designed dual-syringe pump. A servo loop system accurately controls the motion of the metering pump's pistons by measuring the motion of the pump-motor shaft. During volume displacement the two syringes are used alternately, so that intake and delivery of solvent are synchronous.

This design requires a switching valve to connect the syringes alternately with the solvent reservoir and then to solvent delivery (see Fig. 2). A complex SDS control system was designed to coordinate the servo-driven metering pump with a four-port motor-driven rotary valve.

After metering, the solvent pressure has to be amplified to the pressure on the column by a high-pressure booster pump. This second pump is a diaphragm pump operating at a stroke frequency of 10 Hz. However, this allows only a period of approximately 40 ms to fill the cavity under the membrane.

Coupling the metering pump to the high-pressure pump

directly would cause excessive pressure spikes during the strokes of the high-pressure pump, leading to damage of the metering-pump seals and the rotary valve. There are two solutions to this problem. One would be to start and stop the metering pump. This would result in noisy operation and considerable stress on the metering pump's motor, gears, and bearings. The other solution is to add a low-pressure compliance, which temporarily stores solvent, allowing continuous metering pump operation and improving mixing performance.

To reduce the flow ripple produced by the high-pressure pump, there is a damping unit between the solvent outlet of this pump and the column. In essence, it is a reservoir filled with a compressible liquid which is separated from the solvent by a membrane.

The solvents are stored in three reservoirs holding one liter each. To prevent penetration of the LC system by dirt particles, a filter with a 10 μm pore size is installed. The reservoirs are purged with constant helium flow to prevent saturation of the solvent with air.

Metering Pump and Rotary Valve

Fig. 3 shows the metering pump and rotary valve assembly. The main requirements for this pump are a precise flow rate and, to avoid solvent problems, a low linear ve-

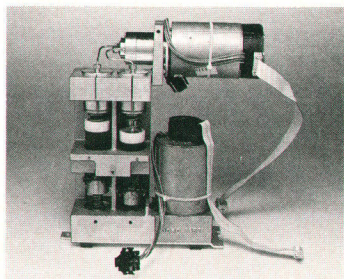
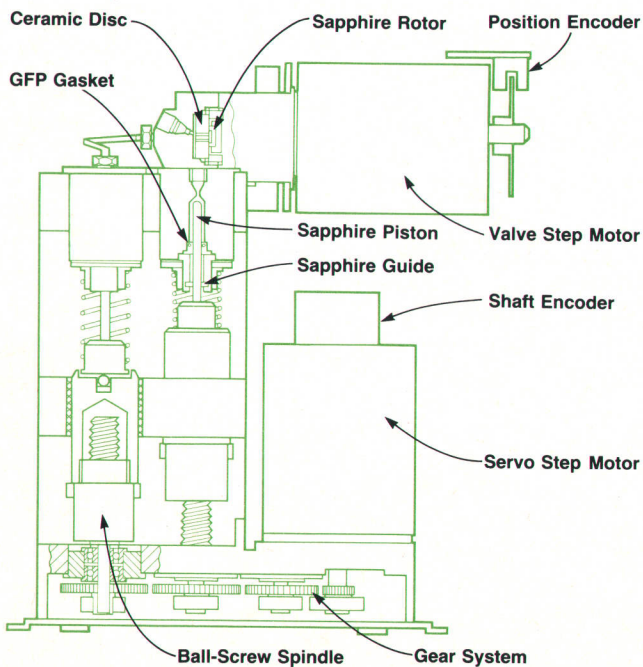


Fig. 3. Metering pump and rotary valve assembly. High-precision sapphire pistons and a high-performance drive system provide accurate volume displacement.

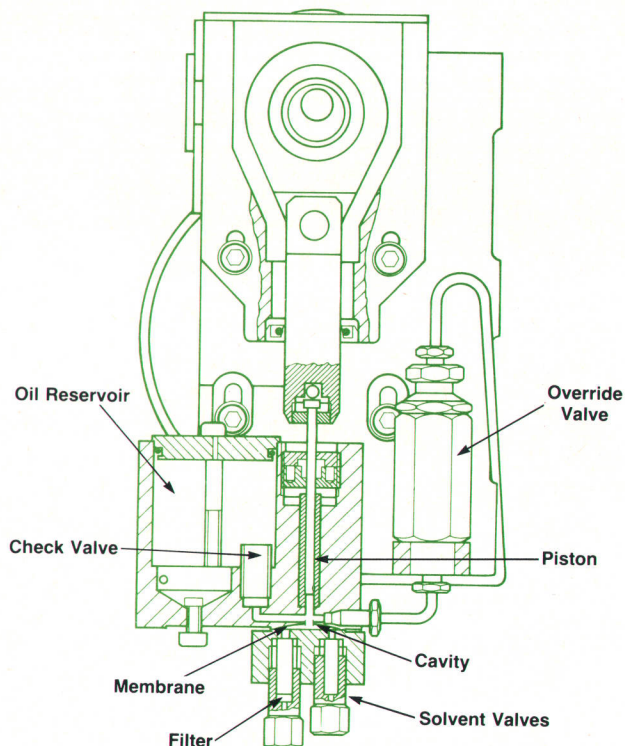


Fig. 4. The high-pressure pump has no suction, but delivers any solvent input to the column against backpressures as high as 40 MPa.

locity when sucking in solvent. The design uses high-precision sapphire pistons and a high-performance drive system to do volume displacement. Two syringes are used alternately to prevent problems caused by fast solvent intake.

The metering pump system is driven by a step motor electrically controlled by a motor drive board. Motor movement is sensed by a shaft encoder with a resolution of 0.25 degree mounted on top of the motor. To achieve the re-

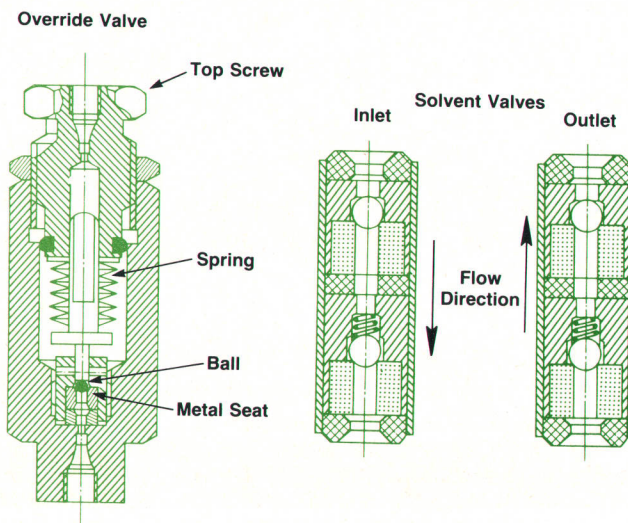


Fig. 5. Override and solvent valves of the high-pressure pump.

quired flow resolution—for example, 6.7 nL—a gear is used to transmit motor movement to the piston. A ball-screw spindle translates the circular movement of the gear into linear movement of the piston; it is spring-loaded to eliminate backlash. The decision to use a ball-screw spindle was based on its low friction, precise pitch, and high reliability. The sapphire piston of the pump is assembled under ball-loaded conditions and the movement is guided by a sapphire ring. The seal problem is solved by a solvent-resistant GFP gasket. The displacement volume of the metering pump is approximately 100 μL per syringe.

A four-port rotary valve driven by a variable-reluctance motor connects the syringes alternately with the solvent reservoir for solvent delivery. When the piston on the forward stroke reaches the end of a cylinder, the control system waits for the pressure stroke of the high-pressure pump. Then it stops the servo drive and turns the rotary switching valve through 90 degrees, reversing the connections of the pistons. The servo drive is restarted, running in the opposite direction.

The rotary valve avoids the common problem of checkvalves, which need a certain amount of backflow to close. The amount of backflow needed depends on the flow rate, on solvent properties, and on the valve geometry, and is generally unpredictable. The main design challenge was to find a combination of materials for the valve rotor and

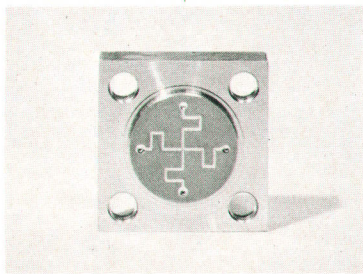
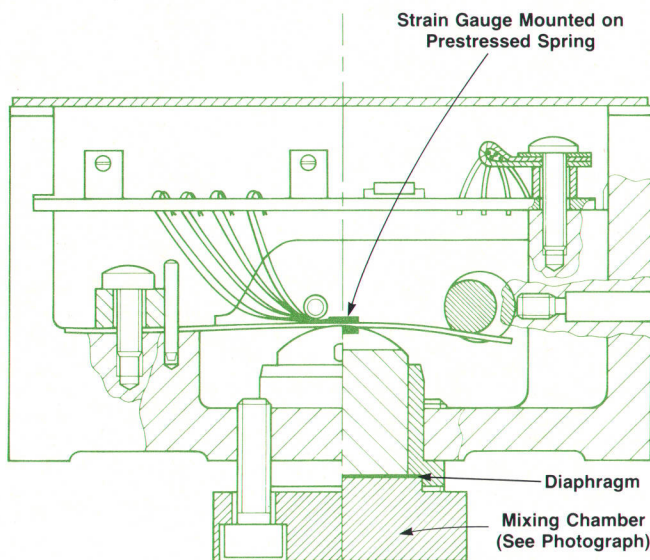


Fig. 6. The low-pressure compliance (LPC) connects the metering pump to the high-pressure pump. The contributions of the three solvent channels are combined in the mixing chamber (photo). The deflection of the diaphragm of the LPC is measured by a strain gauge system mounted on a prestressed spring.

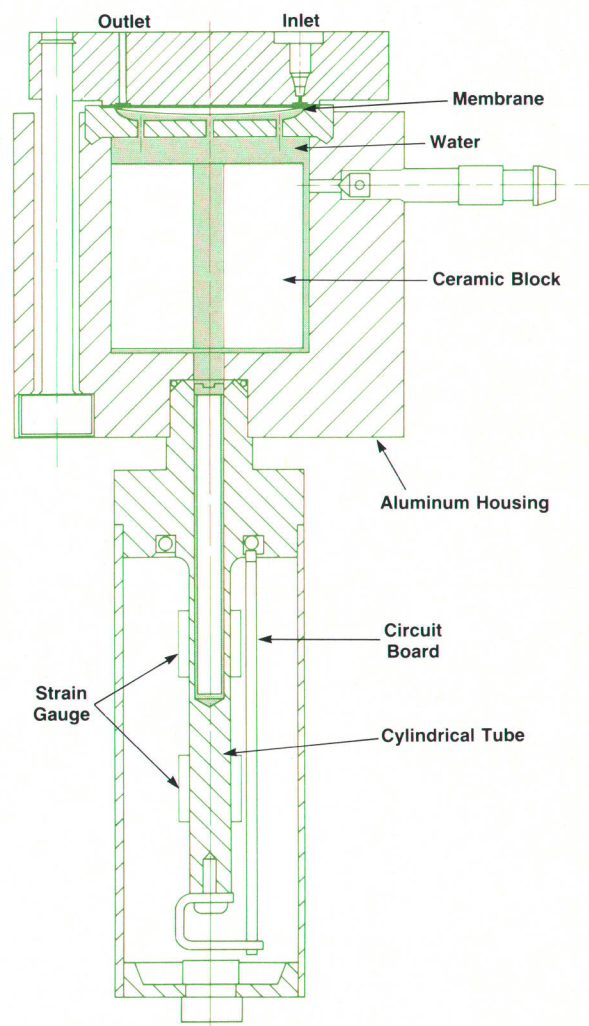


Fig. 7. In the damping unit, flow ripple is reduced and the high pressure is measured with a strain gauge bridge mounted on a cylindrical tube.

stator that have low friction, low wear, good sealing performance, and high reliability. A sapphire rotor and a ceramic disc stator were selected and extensively tested to match the requirements.

The connection between the metering pump and the rotary valve is a pair of stainless-steel capillaries. The final positions of the rotary valve are controlled by light-actuated switches.

High-Pressure Pump

The high-pressure booster pump (Fig. 4) produces the flow through the column. This pump is unable to suck in solvent, but delivers any solvent input to the LC system against backpressures as high as 40 MPa. The design is based on the highly reliable diaphragm pump used in the HP 1080 LC, which is free of seal and wear problems over this entire pressure range. The pump is driven by an asynchronous motor operating from the ac line. The motor is inexpensive and its high moment of inertia makes it an excellent choice for a fixed-frequency pump drive.

For the 1090 LC, the 1080 pump design had to be modified not to suck in solvent. An oil valve added to the oil circuit makes it possible to refill the oil side while the plunger travels back. The metering pumps generate enough pressure to fill the chamber of the booster pump by deflecting the diaphragm. When the booster pump completes its high-pressure delivery stroke, the diaphragm is pressed against the flat surface of the pumphead, which means that under high pressure the stress on the diaphragm is low because it is undeflected. This should further enhance the pump's reliability.

When the piston starts to travel backwards, the solvent contained between the inlet and outlet valves expands and the pressure drops. When this pressure has arrived at a value about one bar below the pressure in the compliance chamber, the inlet valve opens and solvent flows into the pump body cavity, forcing the membrane to bend towards the oil section. As soon as the piston reverses its movement the inlet valve closes, and oil pressure is built up until the system pressure is reached. The outlet valve then opens and all the solvent between the membrane and the pumphead is delivered to the system. While the piston keeps traveling until it reaches its lower position, further pressure is built up in the oil above the membrane which is finally released via the override valve to the oil reservoir. Refill occurs as the piston travels back after reaching its lower position. Since the piston stroke volume is substantially larger than the maximum volume of solvent delivered to the system per stroke, the balance is filled by oil taken from the oil reservoir through a check valve.

In the override valve (Fig. 5), a ruby ball is pressed with a spring on the metal seat with a force representing a pressure of 440 bar. Relief pressure is adjusted by setting the top screw. In case of relief, oil flows around the ball through a small bore in the housing into the main compartment of the override valve and then out to the oil reservoir through a capillary.

Solvent inlet and outlet valves use the same cartridge, installed in different directions. The solvent ball valves (Fig. 5) are built up of two sapphire seats, two ruby balls (one is spring loaded), and three polyimide seals installed in a tube. Spring loading of one ball in the valve cartridge is necessary to prevent sucking of solvent from the low-pressure compliance and mixing chamber.

Low-Pressure Compliance

The contributions of each solvent channel to the total flow are mixed together in the chamber of the LPC (Fig. 6). Since there is a continuous delivery from each channel, the LPC also temporarily stores the flow volume delivered from each channel for the time the piston of the high-pressure pump is on its pressure stroke and no flow can leave the LPC. To prevent damage from blockages in the high-pressure pump, the deflection of the diaphragm is measured by a strain gauge system mounted on a leaf spring. Flow volume filling the chamber moves a metal cylinder which bends the spring. An electrical circuit transforms the mechanical movement sensed by the strain gauge bridge into an electrical signal which is sent to the system controller, which monitors both low-pressure and high-pressure measurements. The spring is prestressed such that there

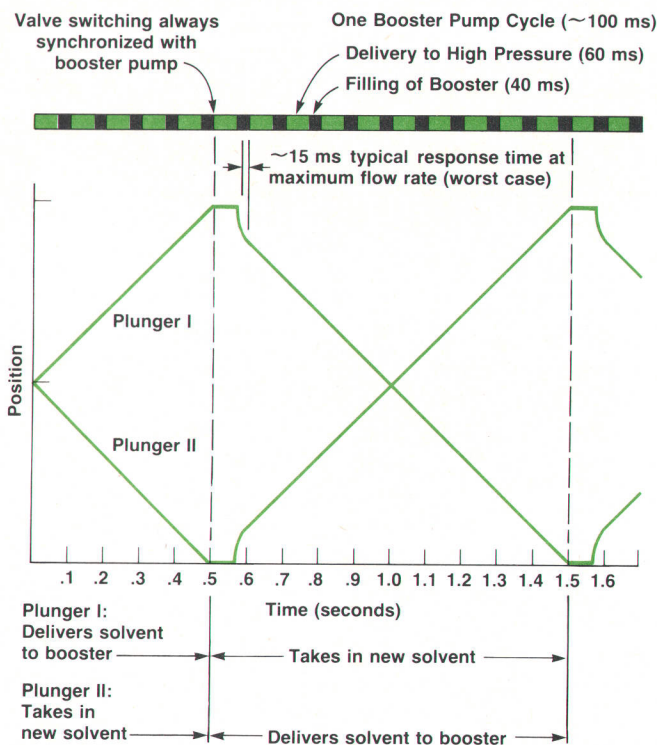


Fig. 8. Required motion of the metering pump pistons.

will only be a change in the output signal when the pressure exceeds 2 bar.

Mixing of up to three solvents takes place in a normal working volume of only $9 \mu\text{l}$. In designing the LPC, we had to guarantee that when the high-pressure booster pump is being filled, the LPC diaphragm is in a fixed position so that only the metering pump determines the flow. The LPC diaphragm is spring-loaded so that it returns to its undeflected position when the booster pump is filled, thereby ensuring reproducible flow.

Damping Unit

In the damping unit (Fig. 7), flow is damped (flow ripple reduction) and the high pressure in the system is measured. The damping function is provided by an aluminum housing partly filled with water as the compressible medium and a solid ceramic block which compensates for the different coefficients of expansion of water and the aluminum housing. This allows operation from 0 to 55°C and storage from 40 to 70°C .

High pressure is measured with a strain gauge bridge mounted on a cylindrical tube which is filled with water and a solid metal bar. The electrical circuit that outputs a voltage proportional to the pressure measured is mounted on a bracket on the extension of the metal cylinder.

Design Requirements for the SDS Electronics

Since a metering system does not use feedback to determine rate of flow, but relies instead on displacement of solvent, it is important to maintain precise control of the motion of the pistons that displace the solvent. A closed loop system is used in the part of the SDS where the solvent

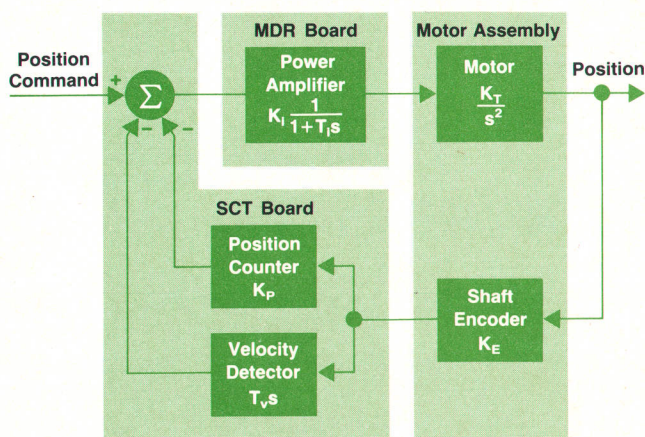


Fig. 9. A PD-type (proportional plus derivative) servo loop is used to control the motion of the metering pump pistons.

is metered.

The metering pumps have a dynamic range of 1:5000 with continuous movement, as described in the previous sections. But once per stroke their direction has to be changed and the rotary valve has to switch (see Fig. 8). The pistons must stop for this to happen. The driving system that produces the piston movement then has to catch up to the position where it would be if there were no such stop time. This requires a five-fold faster movement of the pistons—an actual dynamic range of 1:25,000. However, with the pistons moving that fast, overshoot has to be negligible to guarantee accuracy of flow. This puts great demands on a drive control system.

Implementation

For measuring the position of the motor shaft, an HP HEDS-5030 Incremental Optical Encoder was chosen for its low additional inertia, high reliability and low cost. With 360 slits and three channels, it uses quadrature decoding to produce 1440 pulses per revolution (i.e., 0.25° angular resolution).

The rotary valve positions are detected by an absolute

position encoder. Two light sensors on the rotary valve sensor board detect every 45° incremental position (0°, 45°, 90°) of the rotary valve, which moves with a 15° increment of rotation. The motor that drives the rotary valve has to have an extremely good torque-to-inertia ratio to ensure fast switching. A three-phase, size 20, variable-reluctance (VR) motor was selected because it both satisfies this demand and is cheap and reliable. A further advantage of VR motors is that they do not produce sparks. This is especially important, since some chromatographic solvents can form explosive vapors.

The same motor is used to drive the servo-controlled metering pump. However, this motor has only 24 zero-torque positions or steps per revolution, but the servo loop requires 1440 steps per revolution. To fit in more steps on the nonlinear torque-vs-angle curves of VR motors creates further demands for the drive control system. A non-dc motor also needs to be commutated to determine which of the three motor windings the current flows through and at what time.

A PD-type controller controls the servo loop, as shown in the simplified servo loop diagram, Fig. 9. Fig. 10 shows the electronic block diagram of the SDS. By calculating position versus time, the 8041A microprocessor in the LC controller controls the velocity of the pistons and therefore the flow rate. The electronic elements that create the motor commands are contained in the servo control board (SCT). The power to drive the motors comes from the motor driver board (MDR). There is one SCT board and one MDR board for every metering channel.

Servo Control Board

The SCT board is fully digital and can be divided into nine functional blocks (Fig. 11):

- Quadrature decoder
- Actual position counter
- Command position register
- Velocity detector
- Position and velocity error adders
- Pulse width modulator (PWM)
- Commutator

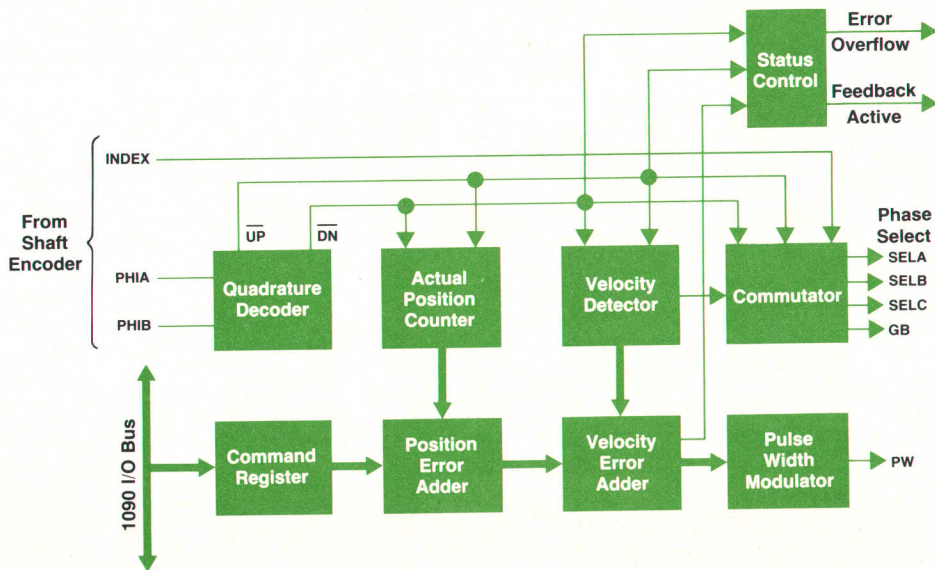


Fig. 10. Solvent delivery system electronic block diagram.

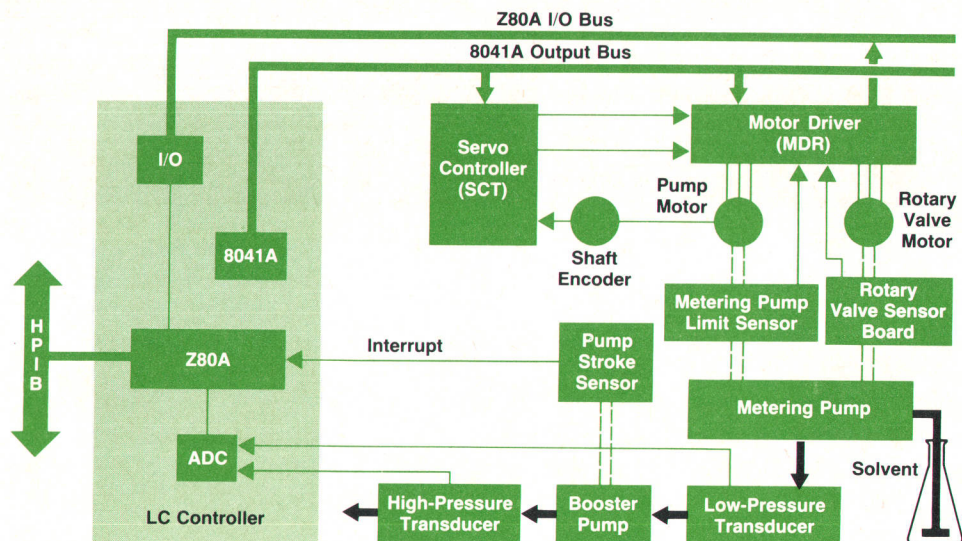


Fig. 11. Block diagram of the SDS servo controller board (SCT).

■ Status control logic.

The quadrature decoder receives the two signals from the shaft encoder and produces either an up or a down pulse on each quadrature transition. Since the UP and DN pulses are synchronized with the clock, no further synchronization is necessary.

The UP and DN pulses are counted to determine the absolute shaft position. A 12-bit coded result is provided by the actual position counter. The setpoint data is loaded into the command register from the 8041A.

In addition to position feedback, velocity feedback is used in the servo controller, giving it its PD-type characteristic. The motor velocity is computed by counting the number of encoder states over a fixed period of time. The velocity feedback goes to the velocity error adder and also to the commutator circuitry.

There are two sets of adders. One is used to derive the position error, while the other adds the velocity to the position error to produce the motor command word to the PWM.

The PWM contains a set of counters, which are incremented or decremented depending on the sign of the command signal. The counting frequency is 1 MHz, allowing 32 error states to cover the output duty cycle range of 0 to 80% at a 25-kHz switching frequency.

Commutation is accomplished by the use of a ring counter that has two subrings and a PROM that contains the commutation pattern to be used. The velocity derived from the velocity detector provides phase advance for increased performance and higher speeds. Phase overlapping is used to improve the performance of the metering pump motor. This means that sometimes current flows through two motor windings at the same time. The motor driver board (MDR, see Fig. 12) has a current regulator which controls the sum of the currents through all motor windings. Switching on two phases results in approximately half the nominal current through each winding, which results in only half the power going into the motor. To compensate for this, the gain of the motor driver is increased by $\sqrt{2}$. This is done by setting a gain bit (GB) at the com-

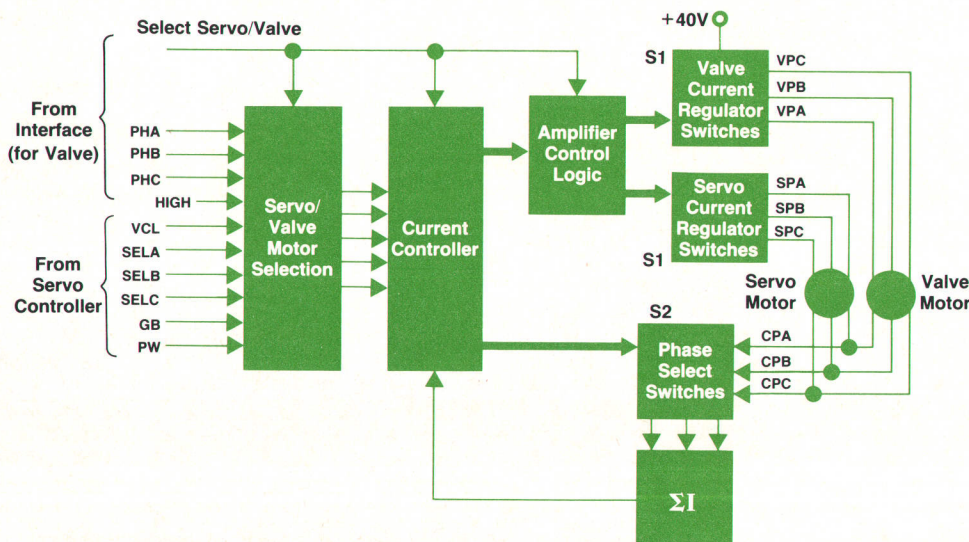


Fig. 12. Block diagram of the SDS motor driver board (MDR).

mutator PROM when phases overlap.

Motor Driver Board

Fast response and a linear characteristic are basic requirements for good closed-loop performance. To meet these requirements, a switched mode power amplifier is used because of its good efficiency. Constant switching frequency assures no audible noise. No analog input signals are used, thereby improving immunity to electrical noise. Both VR motors (metering pump and rotary valve) are connected to the MDR board.

Since only one motor has to be driven at a time, it is possible to switch the power amplifier between the two motors. A select signal from the LC controller determines which set of control signals has to be used. The selected set is connected to the input of the current controller, which in turn controls six current regulator switches (one for each motor winding) and three phase select switches according to the amplifier control logic. The sum of all the currents flowing through the phase-select switches is converted into a voltage and fed to the current controller. The use of a bridge amplifier with current feedback allows very accurate control of current through each motor winding and thus very precise control of motor movement.

The output stage is a half-active switched-mode bridge amplifier (Fig. 13). Three states are possible. When S1 and S2 are closed, current flow increases and tries to reach the maximum value (I_{max}) exponentially. With S1 opened, current decreases to zero from the value actually reached, also exponentially. During these two states the current can be measured as a voltage drop across the sense resistor. With

both switches open, the current decrease is also exponential, but the final value is the negative amount of the maximum current. Therefore, current through the windings goes to zero faster.

Two of the input signals to the current controller (Fig. 12) are the pulse width signal PW (magnitude and frequency) and the gain bit GB, both from the servo controller. The product of these two signals forms the setpoint for the current. The difference between the setpoint and the actual current is integrated. The polarity of the integrator output signal determines the state of the current regulator switches. Therefore, the power switching frequency is the same as the input pulse frequency.

System Monitoring

Beyond their purely functional role, the SDS electronics also monitor pressure to prevent damage to any part of the liquid chromatograph through which solvent flows after solvent delivery.

High pressure, measured by a strain gauge bridge in the damping unit, is amplified by the high-pressure transducer. The controller stops the flow if the pressure exceeds a user-definable limit. This measurement is also used to detect high rates of pressure increase. Over 20 bar/second, the rate of increase of flow rate is reduced to prevent damage to the column.

The measurement of the deflection of the diaphragm in the low-pressure compliance is amplified by the low-pressure transducer. The low-pressure signal is used to reduce the flow rate to overcome problems like gas bubbles introduced into the system. If the low-pressure value reaches

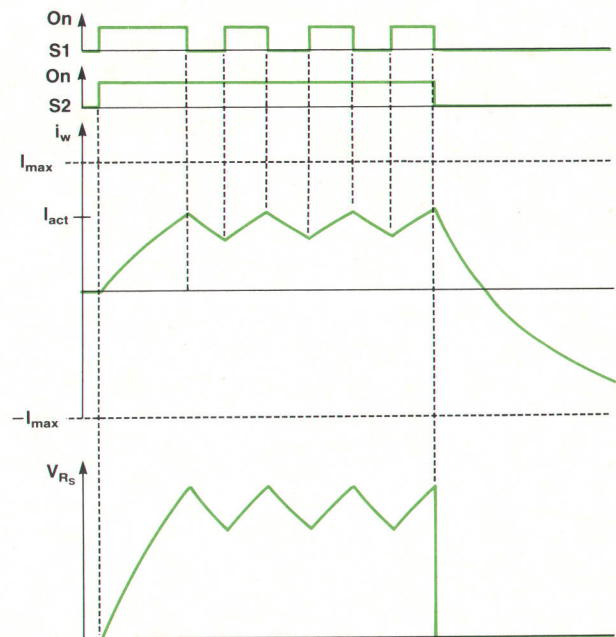
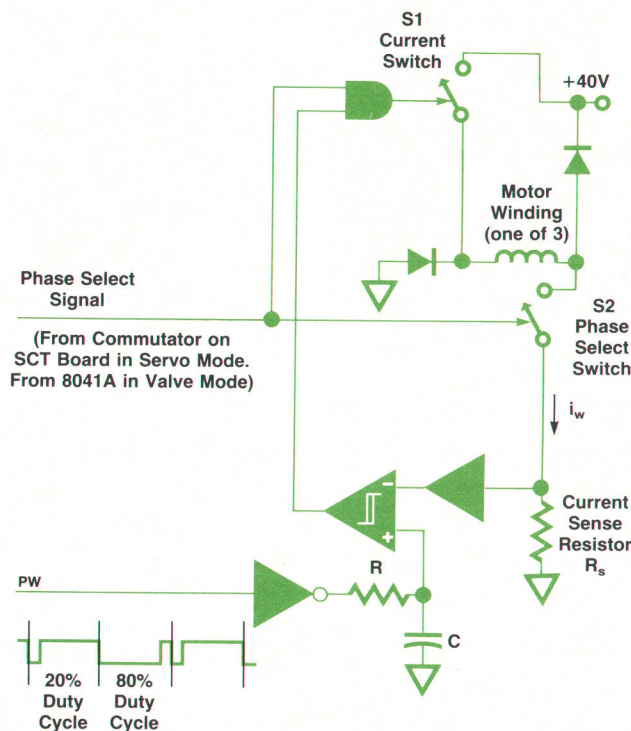


Fig. 13. Output stage of the motor driver is a half-active switched-mode bridge amplifier. The switches S1 and S2 are controlled by the amplifier control logic in Fig. 12.

maximum, flow is reduced to zero, since there may be a blockage in the high-pressure system.

Several light-actuated switches are used to detect the end position of the metering pump pistons and the rotary valve rotor. The metering pump limit and the rotary valve sensor produce signals. However, these can be static over a long period of time, and a failure of any kind might be missed by the LC controller. So all signals are derived from a pulse response signal sent back from the light sensors. This dynamic check, together with some redundancy in the system, enables the electronics to detect component failures, short or open circuits, and missing or incorrect cables, and to put the system into a safe state when it detects a problem.

Automatic Liquid Chromatograph Injection and Sampling

by Wolfgang Kretz and Hans-Georg Härtl

FOR HIGH SAMPLE THROUGHPUT and reduced operating costs, a modern liquid chromatograph needs automatic sample handling and injection capabilities. The HP 79846A Autoinjection Module for the HP 1090 LC System (Fig. 1) is designed to make sample injection easy, accurate, and automatic, thereby freeing the laboratory staff from routine manipulations. An optional automatic sampling device, the HP 79847A, makes it possible to load up to 100 samples and let the system operate unattended—for example, overnight. Thus the HP 1090 gives the user a choice of sampling modes—fully automatic, manual loading with automatic injection, or entirely manual.

Auto Injector Module

Some of the features of the 79846A Autoinjector Module are:

- Programmable injection volumes (e.g., from 1 μl to 25 μl in 0.1- μl steps)
- Minimized contribution to external bandspreading
- Modular design
- Works with both the vial swivel arm and the autosampler magazines
- Programmable flushing of the metering device syringe after solvent change and for removing air bubbles
- 100% use of the sample
- Upgradable for larger injection volumes (maximum injection volume is 250 μl)
- Safety design, e.g., all steps of the injection cycle are sensor-controlled.

Operation

The 79846A has four main assemblies (see Fig. 2). They

Acknowledgments

We would like to thank Fred Strohmeier who designed the metering pump and the rotary valve, Klaus Witt who contributed to the servo electronics, Hans-George Weißgerber who designed the low-pressure compliance, Hans-Georg Härtl for his design of the damping unit, Günter Schäfele who helped with the mechanical design, and especially Alfons Schmid for his help and guidance during his time in Waldbronn. Last, but not least, our thanks to the scientists in Chuck Tyler's group at HP Laboratories for their contribution and their help in getting started with this project.

are the rotary valve unit, the sampling unit, the metering device, and the flushing valve.

In the normal mode (Fig. 2a) the solvent delivery system (SDS) delivers flow to a six-port rotary valve in which a sampling unit takes the place of the sample loop. Before a sample is loaded, the valve directs the solvent through the sampling unit and onto the column. In this mode the system is always clean and ready for an injection.

In the loading mode (Fig. 2b) an air actuator rotates the

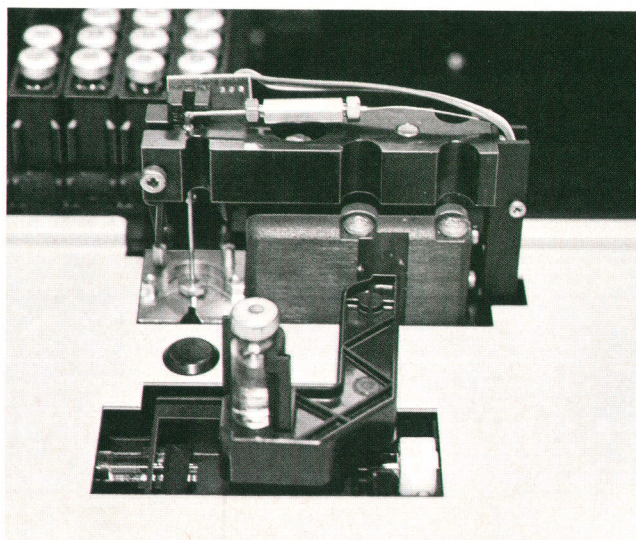


Fig. 1. The 79846A Autoinjector, a module of the HP 1090 LC System, automatically injects the sample into the system. Injection volumes and flushing operations are programmable.

valve and the flow is bypassed directly onto the column. Air pressure lifts the needle and the vial is moved into position beneath it. Then the air flow is reversed and the needle is lowered into the vial. The programmed injection volume is drawn up into the sampling unit by the metering device.

In the injection mode (Fig. 2c) the needle is raised, the vial is moved back and the needle is resealed. The rotary valve returns to its normal mode position, reconnecting the needle loop to the solvent delivery system. All of the sample is pumped out of the injector onto the column and the analysis is started.

In the flushing mode (Fig. 3) the syringe plunger is moved out of the syringe glass barrel. Then the flushing valve directs the liquid flow from the detector cell outlet through the rotary valve in the reverse direction through the syringe. After flushing is completed, the flushing valve switches to its normal mode position and the plunger moves back into its initial position.

Rotary Valve Unit

The high-pressure rotary valve is a standard six-port valve with small internal flow passages combined with a fast air actuator. The actuator has two pistons in its cylinder. These alternately push two racks, which rotate a pinion. A shaft couples the pinion with the rotor of the high-pressure valve. This actuator allows switching of the rotary valve in less than 80 milliseconds, which means that the pressure pulse in the LC system caused by valve switching is minimized. The valve is adjusted to be leak-tight up to 400 bar.

Both end positions are controlled by light-actuated switches.

Sampling Unit

The sampling unit makes it possible to open the loop by

means of a needle and seat at the connecting point. The stainless-steel needle is moved and guided by a double-acting air cylinder, which holds the needle firmly in its seat, forming a leakproof seal. The design of the needle and seat permits good serviceability.

The small needle diameter reduces dead volume in the seat for less peak-broadening. It also reduces evaporation of the sample through the vial septum. Both the upper and the lower positions are sensed by light-actuated switches.

In the arm that holds the needle is a vial sensor. If there is no vial in an autosampler magazine position, the autosampler continues without injection to the next vial.

A user who has no autosampler can work automatically with the step-motor-driven vial swivel arm for a single vial. If an autosampler is installed, the swivel arm provides one additional vial space. When using microvials, the vial in the swivel arm is supported in the vertical direction by a spring. This provides for injection from small total amounts of sample.

Metering Device

The variable-volume metering device is the key component of the autoinjector. In the standard version (for small injection volumes) a gas-tight 25- μl syringe is installed. If a larger volume is required, a 250- μl syringe is available. For changing the syringe, no adjustment is required. The syringe is moved by a guided driver part with two nuts, which are driven by a step motor coupled with a leadscrew. To reduce backlash, the two nuts and the shoulder bearings of the leadscrew are spring-loaded. To couple the motor with the leadscrew, a one-piece coupler is used.

A light switch senses the initial position. From this position, each step draws up 7 nanoliters of sample if a 25- μl syringe is installed. This resolution allows injection of as little as 0.5 μl with acceptable precision.

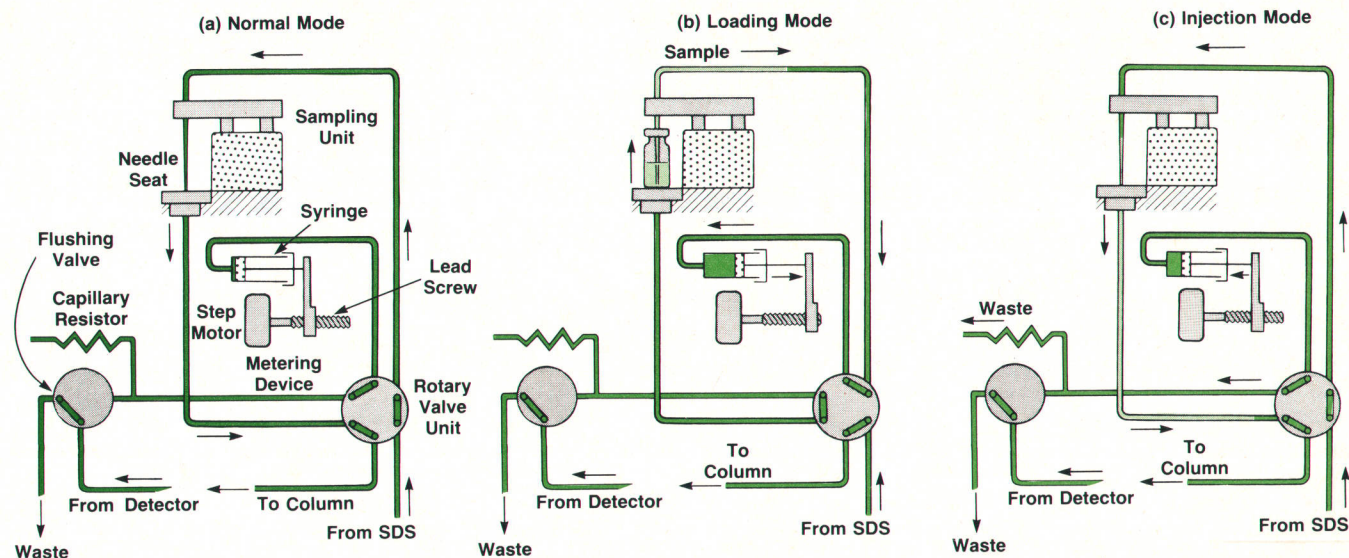


Fig. 2. Operation modes during an injection cycle. (a) In the normal mode, the system is ready for an injection. (b) In the loading mode, solvent flow bypasses the sampling unit while the programmed injection volume is drawn out of the sample vial. (c) In the injection mode, the sample is pumped out of the injector onto the column.

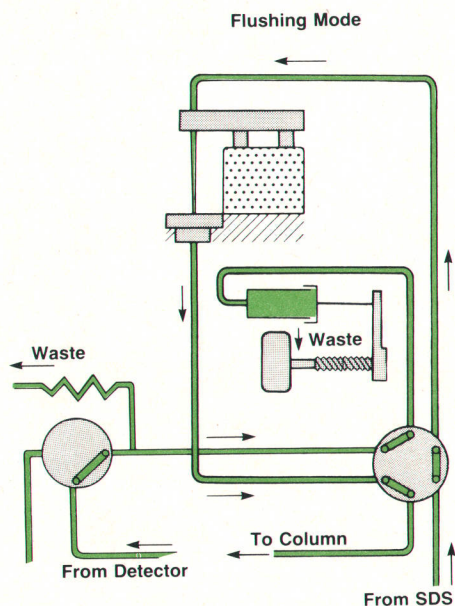


Fig. 3. In the flushing mode, solvent flow is directed through the injection syringe in the reverse direction.

Flushing Valve

The flushing valve is a solenoid-actuated, low-pressure three-port valve. The maximum pressure is 2 bar, which means that in case one of the two valve outlets becomes plugged, the other opens at this pressure. The effect is protection of the detector cell from overpressure.

Automatic Sampling Device

In the past, HP autosamplers have been based on a sample-chain mechanism. The sample vials are located in the links of a chain, which is driven by pneumatic air cylinders to move one vial after the other to the injection point.

The major goals for the new HP 79847A Autosampler design included a simple, cost-effective mechanism without pneumatic actuation, more sample vials, and rapid, random access to the vials.

In the HP 79847A, complex mechanical shapes are made of injection-molded parts, which are assembled by snap connections. The material is PBTP GF for excellent chemical resistance and good mechanical properties. The pneumatic devices of earlier designs are replaced by step motors, and instead of the chain there is an X-Y table with 10 exchangeable magazines, each containing 10 vials (Fig. 4). This principle allows very rapid random access to every sample and the possibility of loading the magazine outside the instrument.

The X-Y table, or carriage, is assembled out of 23 plastic molded parts, but there are only three different types. Each magazine consists of two plastic molded parts and a plastic tube, also assembled by snap connections. The tube at the magazine's bottom is used as a spring, holding the inserted vials in the correct position.

In the X direction, the carriage slides on plastic rails, driven by a step motor. A cogwheel pressed on the motor's axle meshes with a cograil molded on the carriage.

In the Y direction, the magazines holding the sample

vials are fixed on the magazine holders which are moved by a plastic molded driver sliding on two steel rods. The driver's motion is controlled by a step motor via a gear belt.

The complete sampler is held together by a chassis built of sheet-metal parts. The overall design minimizes manufacturing costs.

In operation, two numbers are associated with each sample vial, the magazine number and the vial number within the magazine. A specific sample vial is selected by counting the magazine and vial positions while moving. All autosampler actions are controlled by the central microprocessor which creates the pattern for the motors and counts pulses from various sensors.

The count pulses giving actual-position feedback are generated by four light-actuated switches. Direction control is achieved by two sensors, one to give an absolute signal for the home position, the other to give the count pulses to find the specified position. During positioning, if the expected step count is exceeded before reaching the next position, the whole procedure is repeated.

After the sample has been delivered to the injector, the carriage is always moved back to its home position to avoid position-error accumulation.

Safety and Reliability

All electronics in the injector and sampler use low voltage. To protect the operator from injury from moving mechanical parts, the 1090 cover must be closed before an injection can be started. A drip tray located under the autoinjector collects any leaking solvent and channels it to a waste outlet. A leak sensor in the tray generates an error message when leaking solvent is detected. All injection cycle steps are sensor-controlled. For each step, a preset time is allowed. If any step takes too long or fails, it causes an aborted injection and displays an error message. Low air pressure is sensed by a pressure switch. In this case an injection is not possible and an error message is generated. A pressure relief valve protects the autoinjector in case of excessive air pressure. The solenoid valves controlling

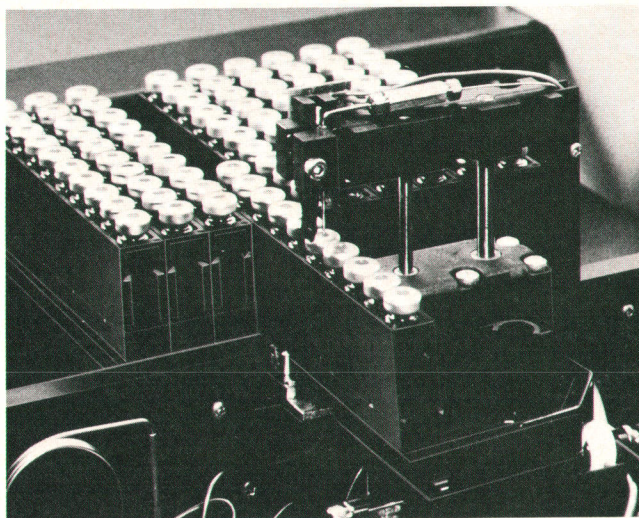


Fig. 4. The 79847A Autosampler provides rapid random access to 100 sample vials.

both the rotary valve and the sample unit are latched valves. This means that in case of a power failure the needle and rotary valve stay in their home positions.

To ensure autoinjector reliability, all dynamically stressed parts and the whole autoinjector module were tested extensively in life tests. Critical parts were redesigned and tested again. All solvent-wetted parts are made from corrosion-resistant materials.

In case of a failure, a set of instructions, executable only in the diagnostic state, allows stepwise execution of the

injection sequence. Control is exercised and error messages are displayed by the HP-85 computer.

Acknowledgments

Many thanks to Henk Lauer, group leader, for helpful discussions during the project. Also thanks to Gerhard Plé, who developed the electronic hardware and software, to Gerard Rozing and Robert Jonker for performance testing, and to Helmut Rößler for his assistance during component testing.

Mobile Phase Preheater Ensures Precise Control of LC Column Temperature

by Helge Schrenker

THE USE OF CONVENTIONAL air-bath thermostats as a means of controlling column temperature in high-performance liquid chromatography is limited to a relatively narrow temperature range if full column efficiency is to be maintained. Particularly at high air-bath temperatures, large axial temperature gradients in the column occur, which are detrimental to column performance. This has been demonstrated by many experiments.¹

In the HP 1090 Liquid Chromatograph, a new type of column thermostat, including a highly efficient, small-volume mobile phase preheater, is used. Suitable adjustment

of the heat transfer in the mobile phase heater and the air heater results in nearly identical temperatures of the mobile phase entering the column and of the air flowing around the column. Thus axial and radial temperature gradients in the column are minimized, leading to a marked improvement of column performance at elevated temperatures.

Importance of Column Temperature

Column temperature has become increasingly accepted as a separation parameter in high-performance liquid chromatography (HPLC). Consequently, the means of maintaining a constant column temperature is now also considered to be an important aspect of HPLC instrument design.

The influence of temperature can be significant. Because its effect is dependent on the substances to be separated, column temperature can be an important means of optimizing separation selectivity. Chmielowiec and Sawatzky² published retention data for polynuclear aromatic hydrocarbons (PAHs) showing reversal of the elution order in some instances when the temperature was changed from 10° to 55°C.

The influence of temperature on column efficiency (plate height)* is mainly determined by the relationship between temperature and the diffusion coefficient of the solutes in the mobile phase, and between temperature and the solute mass transfer in the mobile and stationary phases. According to Melander and Horváth³, the plate height in reversed-phase HPLC may decrease by 30% if the column temperature is increased from 15° to 72°C.

Design Considerations

The column thermostat system for the HP 1090 is designed to meet the following requirements:

*Plate theory asserts that the chromatographic column works like a distillation column. Chromatographic columns are considered as consisting of a number of theoretical plates, each performing a partial separation of components.

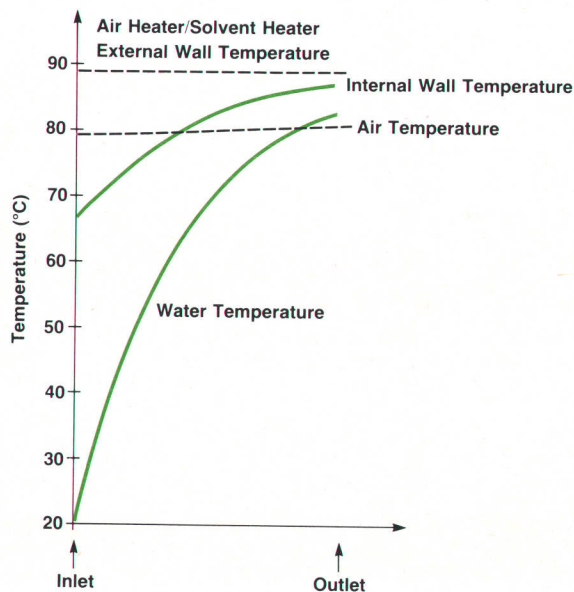


Fig. 1. Calculated temperature profiles in the combined solvent and air heater for a flow rate of 5 ml/min.

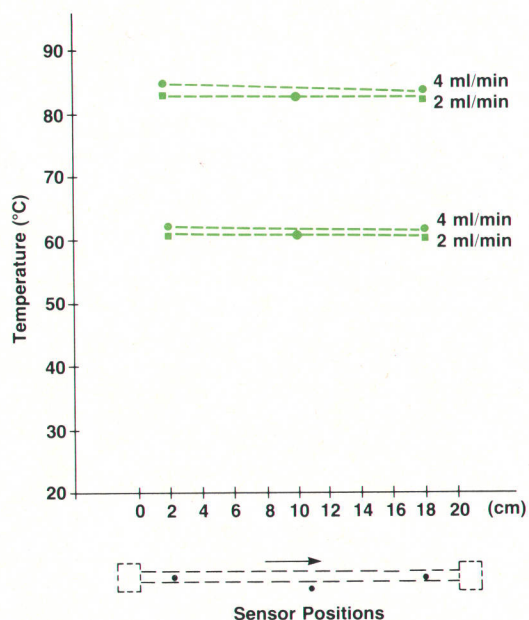


Fig. 2. Temperatures measured in the column 1.5 cm from the inlet and outlet and in air close to the column wall, using the combined solvent-plus-column thermostat. Temperatures for different flow rates and temperature setpoints vary by 1.5°C or less.

- Axial and radial temperature gradients in the column bed should not exceed 1 to 2°C
- Variation of the column flow rate in the range 0 to 5 ml/min must not result in temperature changes in the column bed of more than 1 to 2°C
- Injection of large sample volumes must not cause (temporary) temperature instabilities in the column bed of more than 1 to 2°C
- No part in a column thermostat must exceed a temperature of 180°C (the spontaneous ignition temperature of diethyl ether is 186°C and that of n-heptane is 247°C). Preheating of the mobile phase before it enters the column to avoid large temperature gradients in the column bed has been suggested previously.^{4,5} However, the volume

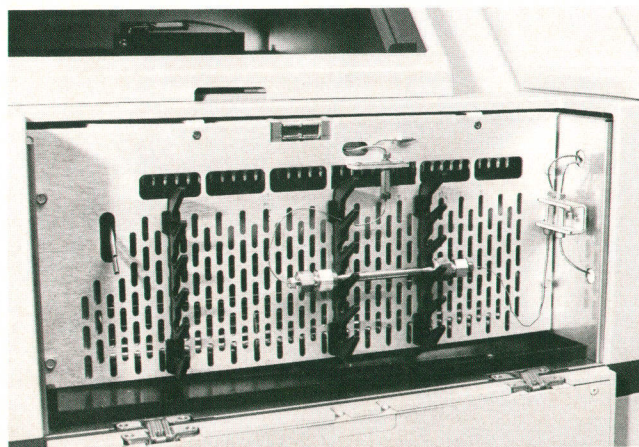


Fig. 3. The column compartment of the HP 1090 LC System is large enough to accommodate most column configurations.

of such preheater columns necessitates their use upstream of the sample injector. Hence a decrease in the temperature of the mobile phase may result from the injection device, which is usually at room temperature. Injection of large sample volumes would result in a temporary disturbance of the temperature equilibrium in the column.

New Thermostat Design

To avoid the problems of previous preheater designs, the HP 1090 uses a small-volume (<2 μ l) heat exchanger between the injector and the column. This was made possible by the discovery that, in very narrow tubes, heat transfer from the tube walls into liquids flowing at subcritical Reynolds Numbers is significantly higher than the theoretical values for laminar flow.

To ensure nearly identical temperatures of the column environment (and thus of the column walls) and of the mobile phase liquid at the outlet of the preheater capillary, the capillary heating block is designed to function simultaneously as the air heater of an air thermostat (column oven). Hence its surface is shaped such that recirculated air flowing across it at a given velocity and surface temperature is heated or cooled just enough to replace the heat loss through the oven walls. Thus the air temperature and

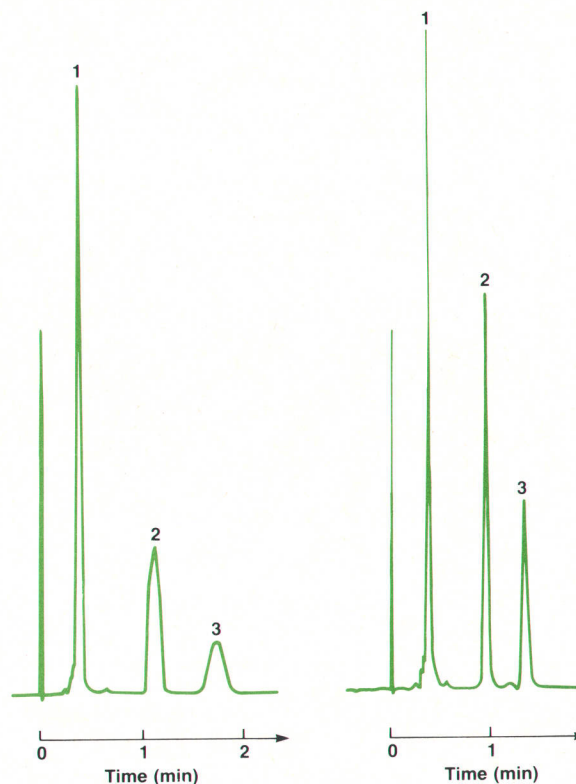


Fig. 4. Examples of chromatograms from a column-only thermostat (left) and from a solvent-plus-column thermostat (right). Column: 100 \times 4.6 mm with 5- μ m ODS Hypersil particles. Solvent: 70% acetonitrile, 30% water. Flow rate: 3.8 ml/min. Sample: (1) aniline, (2) benzo(a)anthracene, (3) 1,2,5,6-dibenzanthracene dissolved in mobile phase. Injection volume: 5 μ l. Thermostat setting: 80°C. UV detector (254 nm), 0.128 A.U. full scale. Chart speed: 1 in/min.

the mobile phase temperature (entering the column) are nearly identical. Fig. 1 illustrates this for certain operating conditions. The surface temperature of this combined solvent and air heater is measured and controlled by a suitable device.

A stainless-steel tube is also die-cast into the aluminum block (parallel to the heating element) for circulating cooling fluid, so that temperature control of the solvent and the column can be extended to ambient and subambient temperatures.

Fig. 2 shows measured temperatures in the column for different flow rates and temperature setpoints. Temperature differences between column inlet and outlet are 1.5°C or less.

Column Compartment

The HP 1090 column compartment (Fig. 3) is insulated from the instrument and the outside world, but is close to the injector and the detector. It is large enough to accommodate most column configurations—for example, it will hold five 300 × 10-mm O.D. GPC (gel permeation chromatography) columns and a switching valve.

The heated column compartment equalizes the temperature of the mobile phase and the column. The injector delivers mobile phase through a 0.15-mm I.D. capillary embedded in the heat exchanger. The capillary volume is only 2 μl. A fan underneath the compartment drives air around and over the heat exchanger, ensuring that the column temperature exactly matches that of the mobile phase

entering the column. The temperature of the column bed is independent of flow rate and sample size.

For reproducibility of retention times, the thermostat controlling the heat exchanger maintains a temperature precision of ±0.6°C. No part of the heat exchanger has a temperature greater than 140°C, an important safety consideration when using flammable solvents.

Results

Fig. 4 shows examples of chromatograms from a column-only thermostat and a solvent-plus-column thermostat under otherwise identical chromatographic conditions. The effect of the new thermostat on peak definition is marked, except on early peaks, where extracolumn band broadening is the dominant effect.

References

1. H. Schrenker, "Effect of Mobile Phase Pre-Heating on High-Performance Liquid Chromatographic Column Performance: A New Type of Column Thermostat," *Journal of Chromatography*, Vol. 213, 1981, pp 243-252. (This Hewlett-Packard Journal article is based in part on this previous paper by the author.)
2. J. Chmielowiec and H. Sawatzky, *J. Chromatogr. Sci.*, Vol. 17, 1979, p. 245.
3. W.R. Melander and Cs. Horváth (Editor), *High-Performance Liquid Chromatography: Advances and Perspectives*, Vol. 2, Academic Press, New York, 1980, p. 192.
4. R.J. Perchalski and B.J. Wilder, *Anal. Chem.*, Vol. 51, 1979, pp. 774-776.
5. H. Schrenker, *CZ-Chem.-Tech.*, Vol. 1, 1972, pp. 73-78.

A Low-Cost LC Filterphotometric Detection System

by Axel Wiese, Bernhard Dehmer, Thomas Dörr, and Günter Höschele

A COMMON TYPE of detector for liquid chromatography is the UV/Vis (ultraviolet/visible) absorbance detector. Light of known spectral characteristics is directed to a flow cell where it passes through the liquid coming from the column. A photodiode is used to measure the light absorbed by the sample. A plot of absorbance versus time is the chromatogram, the desired result of the analysis.

Of the two UV/Vis detectors available for the HP 1090 LC System, the lower-cost detector is the HP 79881A Filterphotometric Detector. The other, a diode array detector, is described in another article in this issue.

The filterphotometric detector offers more flexibility and better detectability and selectivity than other detectors in its class. Generally, low-cost absorbance detectors offer a manual change of lamps (zinc, cadmium, mercury, etc.) or filters, but wavelength switching during an analysis or se-

quence is not possible. Programmable detectors use a moving grating or moving photodiodes and are relatively expensive. Our challenge was to provide an economical means of fast wavelength switching for UV/Vis detection, together with full programmability. In addition, compatibility with high-speed LC and microbore LC was required, so we had to minimize peak broadening by designing the proper geometry for a low-volume flow cell.

Optics

The 79881A Detector shines light from a deuterium lamp through an eight-position filter wheel, splits the beam into reference and sample channels, and uses two photodiodes for detection.

A deuterium gas discharge lamp was chosen as the light source for its continuous spectrum of light from 190 to 600 nm. For applications that do not need full detectability,

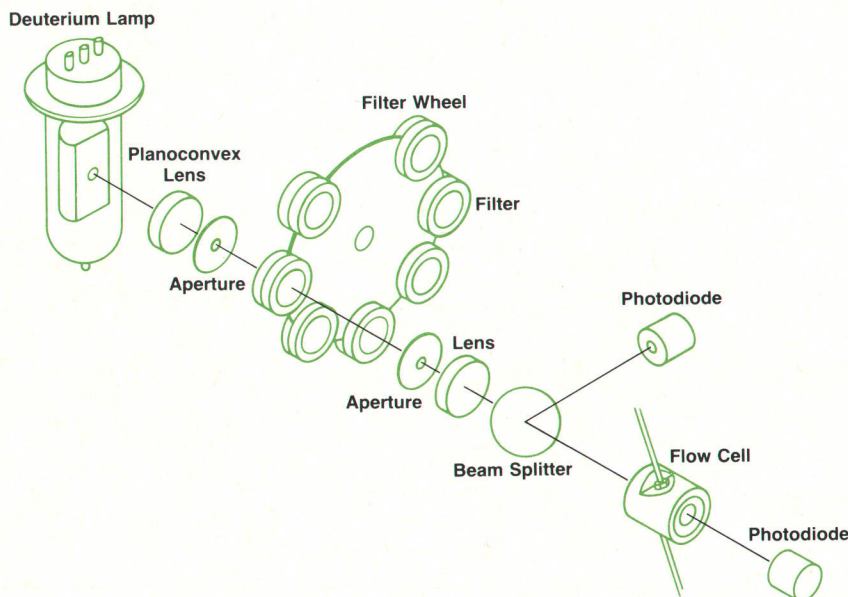


Fig. 1. Optical system of the HP 79881A Filterphotometric Detector.

the lamp's anode current can be switched from high (450 mA) to low (300 mA). This increases the typical lifetime of 500 hours to approximately 1000 hours, with an accompanying reduction of energy emission, which is wavelength-dependent and is significantly higher for wavelengths in the ultraviolet range than for visible light.

The complete 79881A optical system, shown in Fig. 1, contains several components whose functions are perhaps best explained by following the beam through the system. Light leaving the lamp (1-mm circular object) is collected by a planoconvex lens and transmitted through an aperture which minimizes stray light. Interference filters transform the light into monochromatic light. There are seven of these filters on a filter wheel, which is turned by a step motor to one of eight positions. The eighth position blocks the light and is used for dark current measurements. Standard filter wavelengths are 210, 230, 250, 280, 340, 430, and 540 nm, and other filters are available. The bandwidth of these monochromators is approximately 10 nm and they have a transmittance of about 25% in the UV range and about 50% in the visible range. The maximum allowable light in the blocking areas is less than 0.001%.

The beam passes through a second aperture and is then focused such that any chosen wavelength is in focus within the flow cell. The beamsplitter divides the light beam into sample and reference beams with a ratio of 2:1. Splitting is accomplished by small aluminum areas on the surface of a quartz disc; these act as small mirrors. With this design, the split ratio is wavelength-independent.

Light falling onto the photodiodes (which have enhanced sensitivity to UV) generates photocurrents depending on the light intensity. These currents are converted into voltages by operational amplifiers. The optical unit casting contains all of the optical items (lens systems and beamsplitter) as well as the filter wheel assembly and the two photodiode assemblies, which are mounted on preamplifier boards. The deuterium lamp is located in a separate compartment attached to the casting to allow good heat dissipation.

Theoretical Background

The basic equation for absorbance detection is the Lambert-Beer law.

$$A = \epsilon_{\lambda}DC = \log \frac{I_{\text{ref}} + I'_1 + I'_2 + I'_3}{I_{\text{sample}} + I_1 + I_2 + I_3}$$

where:	A	= absorbance in absorbance units (A.U.)
	ϵ_{λ}	= extinction or molar absorption coefficient
	D	= path length (mm)
	C	= solute concentration
	I_{ref}	= photocurrent reference signal
	I_{sample}	= photocurrent sample signal
	I_1, I'_1	= photocurrents produced by stray light
	I_2, I'_2	= additional offsets produced by the preamplifiers
	I_3, I'_3	= dark currents.

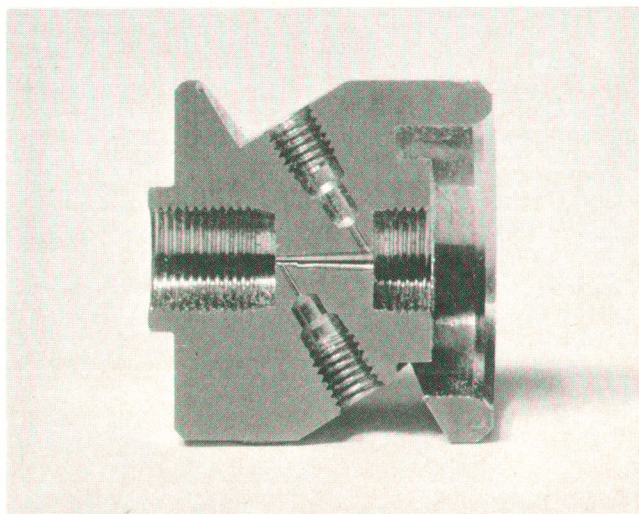


Fig. 2. Cutaway view of the flow cell. Holes as small as 400 μm are drilled with $\pm 25 \mu\text{m}$ precision.

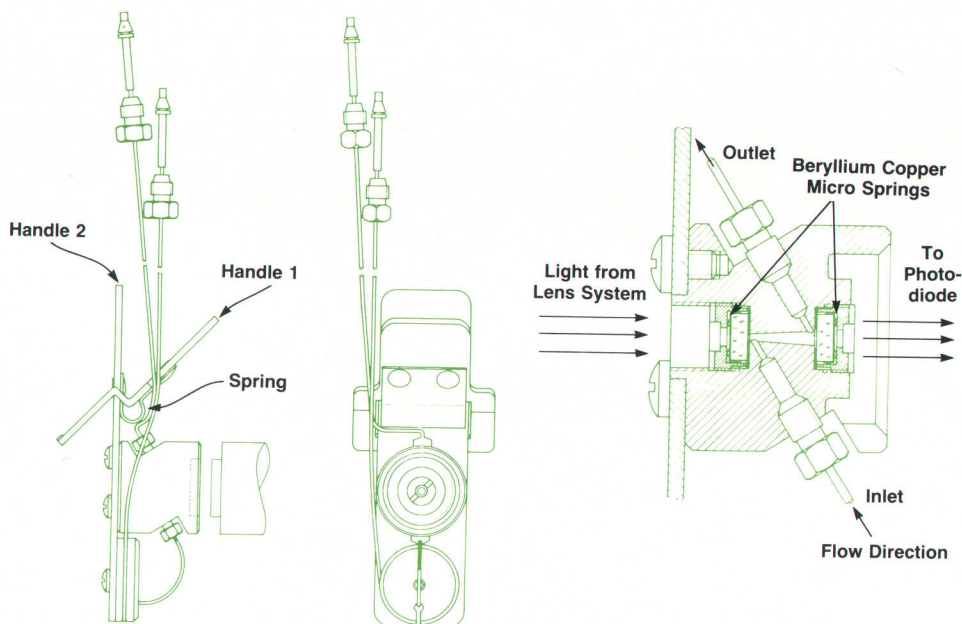


Fig. 3. The flow cell assembly combines high precision with easy replaceability. Changing flow cells is a one-hand operation.

One of the most important limitations is the I_1 photocurrent produced by stray light. There are three types of stray light:

- Light coming from the outside (normally in the visible range)
- Light produced by internal reflections and striking the diode without going through the cell
- Light produced by the "monochromator" at wavelengths other than specified.

The last item is the main limitation on detector linearity. Roughly we can say that stray light has to be less than 1/1000 of the sample light to have a linear relation between absorbance and concentration up to 1.5 A.U. with an error less than 1%. If we increase the bandwidth of the monochromator, additional nonlinearities deteriorate the analytical result.

Flow Cell

Low-volume columns generate low-volume peaks. The flow cell has to preserve the separation efficiency by having a low volume itself. At the same time, the path length needs to be as long as possible, because it is proportional to detectability. The 79881A's flow cell (Fig. 2) has an optimized combination of 4.5- μ l volume and 6-mm path length. Baseline drift, especially with gradient analysis, is strongly influenced by the refractive index sensitivity of the flow cell. The precisely machined conical shape of the cell (which matches the path of the light rays) and optimum imaging despite chromatic errors ensure that these effects are minimized.

In designing the flow cell mechanics we had to look for some new ways to achieve high reliability, easy serviceability, and lower assembly cost. High-precision mechanical parts were developed to join chemical fluidics and optical alignment. Maintenance is a matter of easily removing and/or disassembling the cell. The spring-loaded closed system (Fig. 3) provides its own clamping force and can be inserted or removed with only one hand.

The cell window (quartz) and a spring are mounted within a hollow slot bolt, which is screwed down to the stop cap for sealing the flow cell. A beryllium copper micro spring (see Figs. 3c and 4) was designed that allows reasonable tolerances and the setting of the seal. It clamps the window and braces itself in the slot bolt when mounted. This allows maintenance by standard tools when the windows have to be changed or cleaned.

Fabrication of the flow cell requires high-precision machining within tiny dimensions. Only by special fine-drilling machines and processes for conserving the tools can reproducible fabrication be ensured. The most severe problem is to position the light input hole (inner diameter

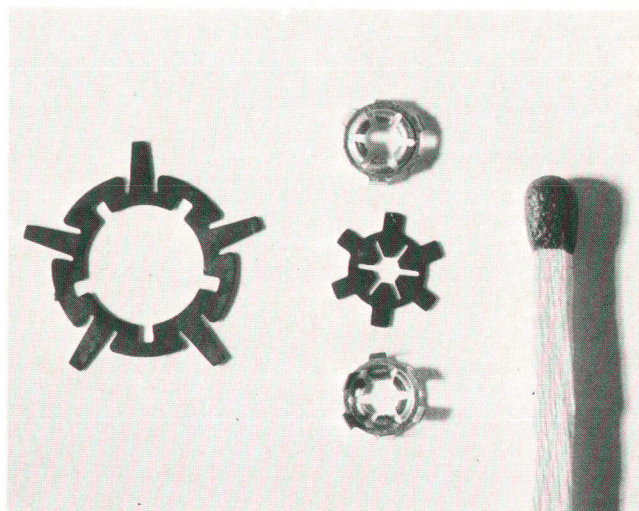


Fig. 4. A beryllium copper micro spring (left) holds the beam splitter in the lens housing. It is used in other locations as well. Another beryllium copper micro spring (right) holds the flow cell window. Top to bottom are the top view of the flow cell micro spring, the raw spring, and the bottom view of the spring.

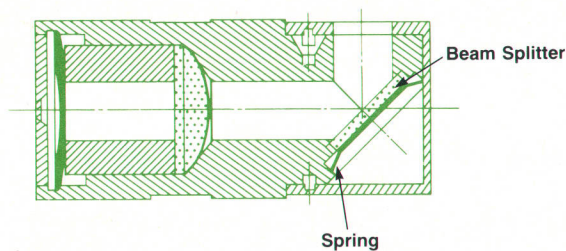


Fig. 5. Lens housing, showing location of micro spring.

0.6 mm) and the light output hole (inner diameter 1.2 mm) with a precision of $\pm 20 \mu\text{m}$.

Wherever feasible, easy mechanical connections such as snap-in devices or spring clamping have been used. A specially designed beryllium copper spring, shown in Fig. 4, is used at several locations for quick assembly and shock protection. For example, in the lens housing (Fig. 5), it holds the beam splitter, a coated quartz disc.

Data Acquisition

Fig. 6 is a block diagram of the data acquisition and processing circuits of the filterphotometric detector.

The reference and sample photodiodes each create at most a 10-nA photocurrent signal, which has to be transformed into an equivalent data word. With a rise time of 100 ms, the analog output bandwidth is about 3 Hz.

The photodiode current is first converted to a voltage by a preamplifier stage, then converted to digital form and sent to the Z80A processor on the filter detector processor board, where absorbance is computed. The absorbance data is converted to analog signals for output to recorders or chromatographic integrators.

The range of the analog-to-digital converters (ADCs) and the digital-to-analog converters (DACs) is determined by the required noise figure of the converting electronics, which has to be a fractional part of the system noise. The limiting noise of the system is the photodiode shot noise, and the current noise of the preamplifier stage should be less than the diode noise. Thus the preamp was the most noise-critical design problem.

For slow precise conversions in the millisecond range we use dual-slope integration. Charge on the integrating capacitor is proportional to the input signal. At the end of a fixed integration period the capacitor is discharged at a constant rate by a constant-current source. During the discharge time, a count clock is allowed to go into a 16-bit counter. When the capacitor is discharged completely, the constant-current source is switched off and integration starts again. Discharge time is proportional to the input signal level. Since a single conversion cycle with a dynamic range of 65,000 would require an expensive design, the cycle is divided into 64 conversions and the results are added. This also makes the conversion less noise sensitive. The capacitor voltage goes through zero more steeply, so comparator hysteresis and threshold noise are not critical, and low-cost components can be used.

After one complete cycle, the data is buffered into the processor. The two ADC channels are fed separately into the processor module.

Data Processing

Detector control by the filter detector processor board is based on a Z80A microprocessor working at a clock rate of 3.9 MHz. This processor uses 8K bytes of EPROM and 2K bytes of RAM. Some memory-mapped interface hardware connects the processor to the ADC/DAC section, to the step motor hardware, and to the lamp power supply. There is also hardware for data input and output, for selection of the filter wheel position, and for lamp control. Parameter setting and detector operation are externally controlled via the 1090 mainframe controller. Communication with this controller is accomplished over an interface between the detector bus and the 1090 I/O bus. No data is transferred, only status and control information.

Data delivered to the Z80A from the ADCs at a rate of 90 Hz is corrected for offset, filtered, and compressed to

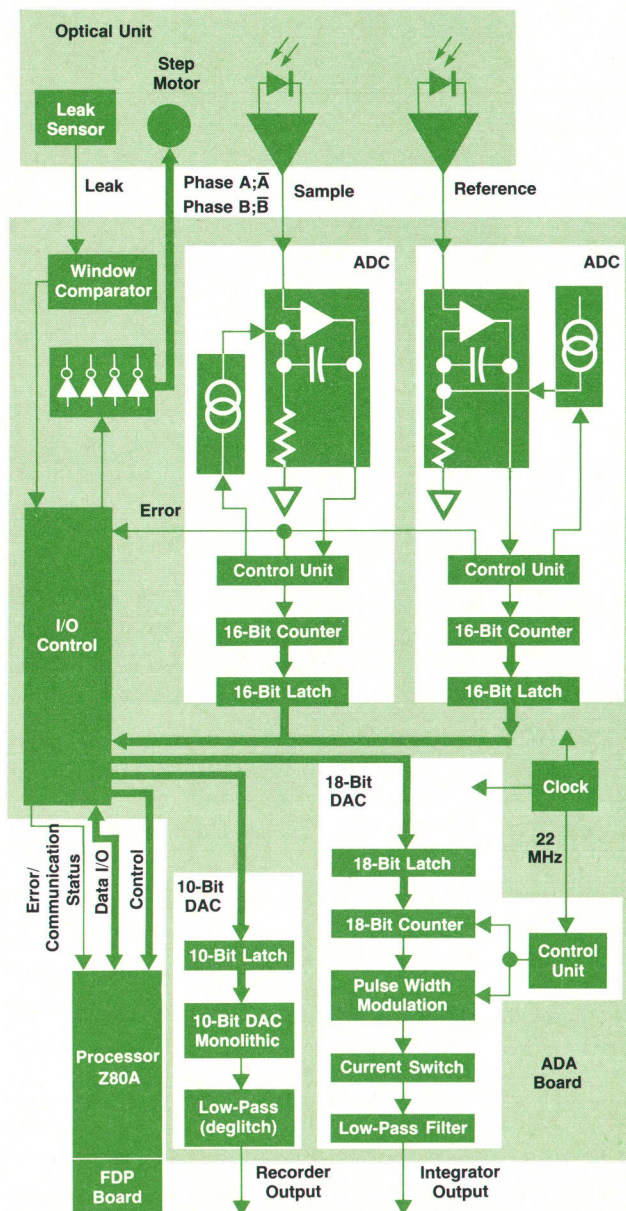


Fig. 6. Signal processing circuits of the UV filterphotometric detector.

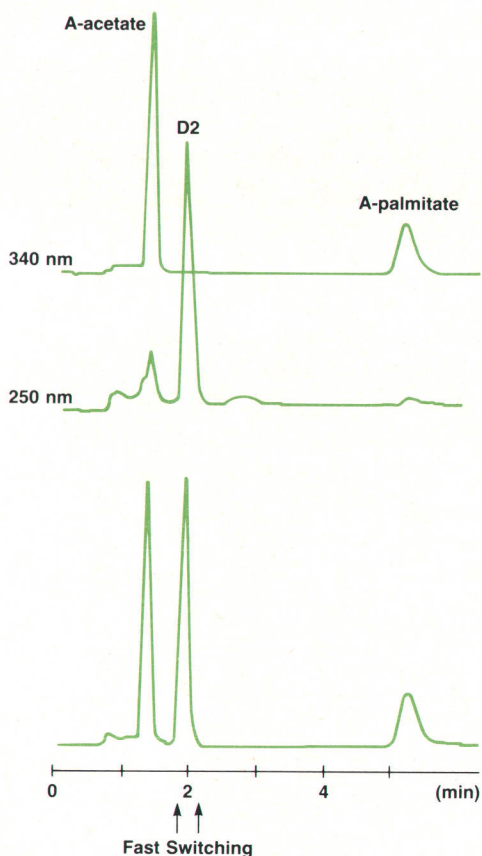


Fig. 7. An autobalance function allows filter changes during a run within two seconds, as shown in the lower chromatogram.

reduce data rate. Further processing of the two channels is done at a rate of 45 Hz. Two filtering operations can be used to obtain rise times of 400 ms or 800 ms, or they can be bypassed for a rise time of 100 ms. The logarithm of the data is taken, absorbance is calculated, and a balancing operation is done, subtracting the zero-balance value from the raw absorbance value. For test reasons the data path from the first filter stage to the balance stage can be by-

passed to get an intensity signal at the DAC outputs.

The last step is to convert the digital data to an analog output proportional to absorbance, depending on the parameter settings for attenuation and zero offset. This is done in a ten-bit monolithic DAC for the recorder output, and in a two-part 18-bit DAC for the integrator output. For the latter conversion, the digital signal is first converted to a pulse width modulated signal, a square wave whose duty cycle varies between 0 and 100%. This is fed to a current switch, which works into the virtual ground of a fifth-order filter configuration. The filter attenuates the fundamental frequency of the square wave by 100 dB to meet the system noise requirements.

Self-Calibration and Test

The filter photometric detector offers self-calibration. An important part is the autobalance function, which allows filter changes during a run within two seconds and without baseline offset (Fig. 7). Self-calibration also includes measurement of offset correction values and calculation of some thresholds, which are used to check the lamp intensity for finding the reference position of the filter wheel and controlling the lamp ignition.

Several problems concerning the lamp, the filter wheel, or the data path can be detected by the processor software. These error conditions, including information from the leak sensor, can be communicated to the 1090 mainframe controller.

Detector Control

The variables for control of the filterphotometric detector appear in the detector method and auxiliary displays of the HP-85 system controller. The variables in the detector method display are part of the current method, which can be stored on a tape cartridge or flexible disc.

On the detector method display the user can set the position of the filter wheel, control the zero offset and attenuation of the recorder output, set the rise time of the integrator and recorder outputs, and set the anode current of the deuterium lamp. On the auxiliary display the user can switch from the absorbance signal to the direct signals from the sample or reference photodiodes.

A High-Speed Spectrophotometric LC Detector

by Joachim Leyrer, Günter E. Nill, Detlev Hadbawnik, Günter Höschele, and Joachim Dieckmann

DURING THE PAST FIFTEEN YEARS, high-performance liquid chromatography (HPLC) has become one of the major analytical techniques for the analysis of complex mixtures of chemical compounds, such as plant extracts, pharmaceutical formulations, or certain drugs in human body fluids. In the course of this successful history, all components of the liquid chromatograph contributing to instrument performance underwent rapid development. In recent years, special emphasis has been placed on the detector area, because this part of the system, which monitors the separated compounds of a mixture, strongly contributes to the selectivity and sensitivity of the analytical method.

A variety of physical and chemical principles are applied in HPLC detectors. These include absorption of ultraviolet (UV), visible (Vis), and infrared (IR) light, measurement of refractive index, fluorescence, electrochemical phenomena (conductivity, amperometry,* voltametry,* polarography), mass spectrometry, and specific chemical reactions. Some of these principles offer distinct advantages for specific applications or application areas. For example, fluorescence and polarography offer extremely high selectivity and sensitivity while refractive index measurement offers nonselectivity and thus general applicability.

UV/Vis Detection

A good compromise, offering medium to high sensitivity combined with excellent selectivity, signal stability, and easy handling, is the UV/Vis absorbance detector, which measures the absorbance A of the solution of a chemical compound in the detector cell. According to the Lambert-Beer law,

$$A = \epsilon_{\lambda}CD,$$

under certain conditions the detector signal is proportional to the length D of the detector cell, the concentration C of the absorbing compound, and the molar absorption coefficient ϵ_{λ} for light of a certain wavelength (Fig. 1). Therefore, a UV/Vis detector can be used not only to detect that something is eluting from the chromatographic column (qualitative analysis), but also to determine the unknown concentration of a compound (e.g., a drug in blood) if in a previous run a calibration has been made by injecting a known concentration of the compound of interest (quantitative analysis). The first UV/Vis detectors operated at fixed single wavelengths using light sources that had narrowband emission characteristics and optical filters. The fact that light absorption at a certain wavelength strongly depends upon

*Amperometry and voltametry are electrochemical detection methods in which electrical charge is transferred between a sample and an electrode (as in a battery), and the current or voltage produced is measured.

the chemical structure of a compound definitely limits the versatility of this type of detector and led to the development of variable-wavelength detectors offering different detection wavelengths, selectable from polychromatic light by means of filters or a monochromator grating. For example, the HP 79881A described in the article on page 26 is a variable-wavelength detector in which the wavelengths are selected by filters. These detectors significantly enhance the versatility, selectivity, and sensitivity of UV/Vis detection in HPLC, but they are not able to help determine the chemical identity or structure of an eluting compound.

Information about the chemical nature of a compound can be derived from its UV/Vis spectrum—absorbance as a function of wavelength—measured under standard conditions. The HP 79875A scanning variable-wavelength detector in the HP 1080 LC was the first commercial instrument of this type. However, the eluant flow in the system had to be stopped to record accurate spectra under static conditions. Loss of time and quantitative data were the price paid for structural information and strongly limited application of the system to very specific problems in chromatographic method development.

The need for correlation of the qualitative and quantitative aspects of UV/Vis detection and recent developments in HPLC column technology led to the formulation of the following development objectives for a new detection system for the HP 1090 LC:

- Instant spectral scanning (no need to stop the chromatographic flow)
- Simultaneous acquisition of chromatographic signals in up to eight wavelength ranges

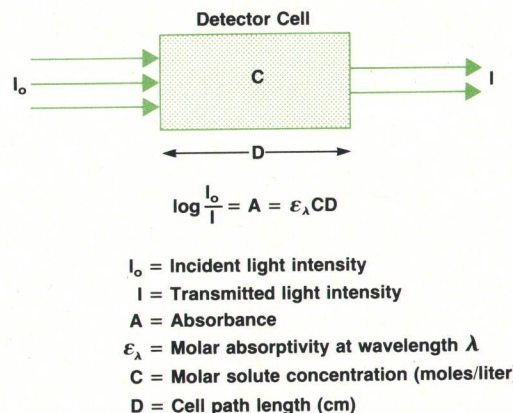


Fig. 1. The HP 1040A HPLC Detection System measures the light absorption of a liquid in the detector cell to determine solute concentrations. The Lambert-Beer law relates absorbance to other parameters.

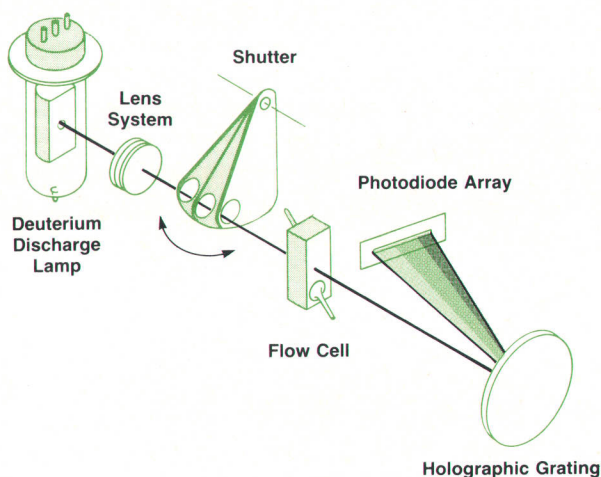


Fig. 2. Schematic diagram of the HP 1040A optical system. Light passing through the sample is dispersed by a holographic diffraction grating and imaged on an array of 205 photodiodes, each covering a 2-nm wavelength range. Thus the spectral light intensities over the wavelength range from 190 to 600 nm are measured simultaneously. Six other diodes on the 211-diode array are used for other measurements.

- Optimization of data rates to meet the speed and sensitivity requirements of high-speed liquid chromatography
- Optimization of hydrodynamic properties for high-speed and microbore liquid chromatography.

These objectives guided the development of the HP 1040A Spectrophotometric Detector, a stand-alone diode array detection system for operation with any liquid chromatograph. It is also available as the HP 79880A, one of the integrated detector modules of the HP 1090 LC family.

System Overview

Fig. 2 gives a simplified overview of the HP 1040's optical design. Polychromatic light emitted by a deuterium lamp is focused into the detector's flow cell by an achromatic lens system. After dispersion* of the light beam on the surface of a diffraction grating, the spectral light intensities over the whole wavelength range from 190 to 600 nm are measured "simultaneously" by a linear 211-element photodiode array, which is read every 10 ms. By repetitive measurements, a three-dimensional matrix is generated showing absorbance data as a function of wavelength and time. Such a 3-D matrix is shown in Fig. 3, together with a chromatographic signal (absorbance vs. time) which can be used for quantitation of a compound, and a spectrum (absorbance vs. wavelength) which provides qualitative, structural information. The data acquired can be monitored on-line on the CRT of the HP-85 system controller and/or stored on raw data files to be further tailored to the user's needs by post-run data evaluation.

Contributions and Key Applications

The following application examples show some of the

*In this article, dispersion is the diffraction of a light beam so that the diffraction angle varies with wavelength, thereby separating the beam's component wavelengths in space. Dispersion in an LC system, by contrast, is the broadening of the chromatographic peaks by dilution, diffusion, and system imperfections.

possibilities offered by the HP 1040A. Dealing with often complex mixtures, the main questions that have to be answered during the development of a chromatographic method are:

- Where in the chromatogram (at which retention time) does the compound that has to be quantified elute?
- Is this peak pure, that is, does it represent only one chemical species?

In the past, time-consuming analytical techniques had to be used to find answers to these questions.

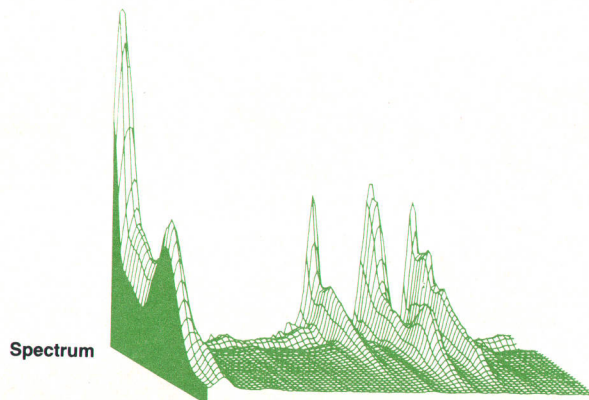
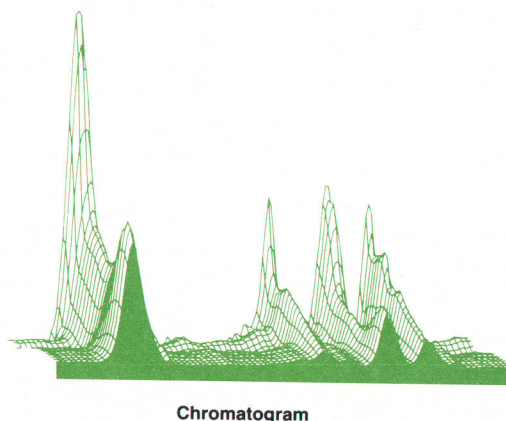
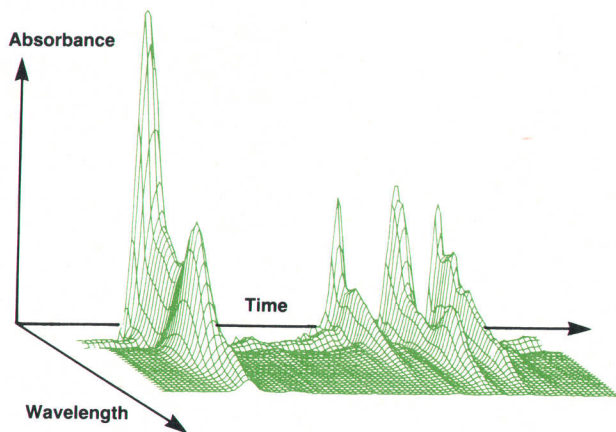


Fig. 3. By repetitive measurements, the HP 1040A generates absorbance data as a function of wavelength and time.

File: COFFEE
 Date: 22:49
 Inj. Time: 565.0 (484.2)
 Attn (mAU): 10
 Zero: 1.8
 Signal: Az 1.8

Wavelength (nm)	1	2	3	4	5	6	7	8
272.10	10	4	4	4	4	4	4	4
285.4	4	4	4	4	4	4	4	4
295.89	4	4	4	4	4	4	4	4
303.20	4	4	4	4	4	4	4	4
320.20	4	4	4	4	4	4	4	4
450.50	4	4	4	4	4	4	4	4
500.100	4	4	4	4	4	4	4	4

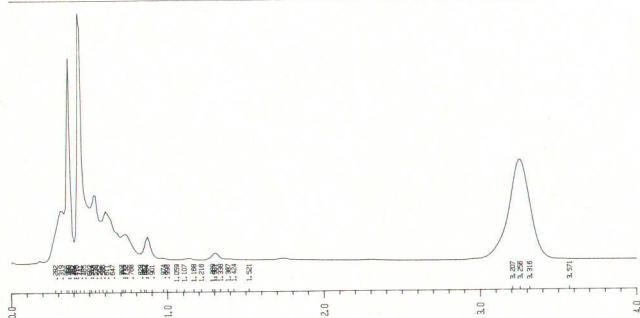


Fig. 4. A typical chromatogram for which peak purity is to be determined.

The quantitative determination of caffeine in beverages like coffee, tea, or cola illustrates the approach taken with the HP 1040A/79880A HPLC Detection System. The chemist chooses appropriate stationary and mobile phases and generates a chromatogram like that shown in Fig. 4. Peak purity can be proven by automatically taking spectra during the elution of the peak of interest at the peak's apex and its inflection points. Fig. 5 illustrates the technique of superimposing these three spectra after normalization, thus confirming peak purity. If the peak is not pure, the spectra will not coincide. The peak's chemical structure can be identified by comparing the spectrum of a caffeine standard with the spectrum of the unidentified peak taken during its elution from the chromatographic column. The result would show that this peak in fact consists of caffeine only. Thus, after two chromatographic runs, the method has proven its analytical relevance. Calibration with a standard solution of pure caffeine prepares the instrument for quantitative measurements.

Simultaneous high-speed signal acquisition at different wavelengths also ensures the detection of all components

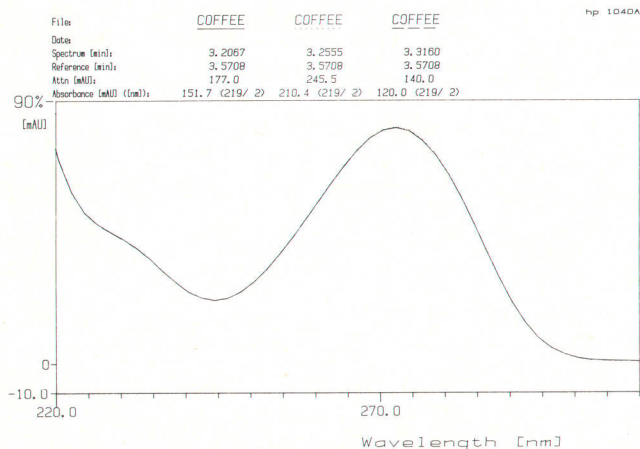


Fig. 5. Peak purity is confirmed by superimposing normalized spectra taken at the peak's apex and its inflection points. If the peak is not pure, the spectra will not coincide.

File: OLE/FLAV
 Date: 09/02/1982
 Inj. Time: 16:30
 Set

Wavelength	Bandwidth	nm
1. 280.0	80	
2. 254.4	4	
3. 217.4	4	
4. 190.4	4	
5. 280.4	4	
6. 310.4	4	
7. 350.20	20	
8. 550.50	50	

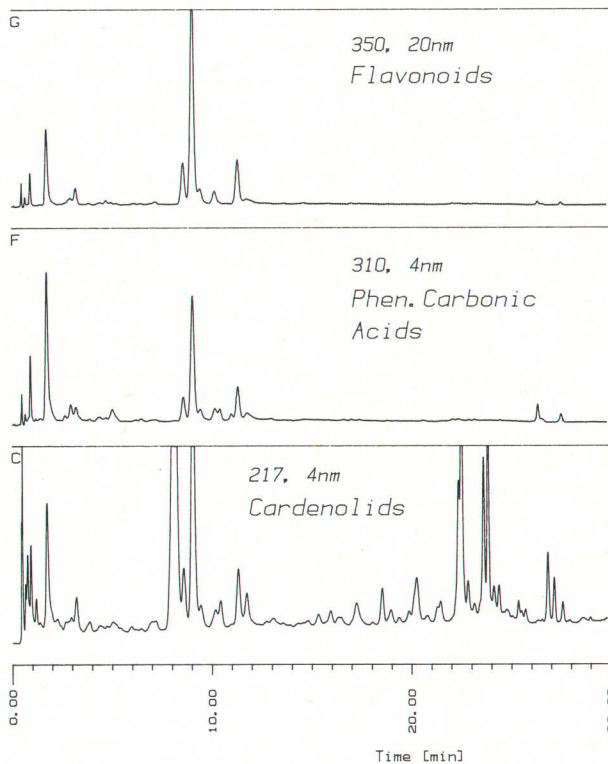


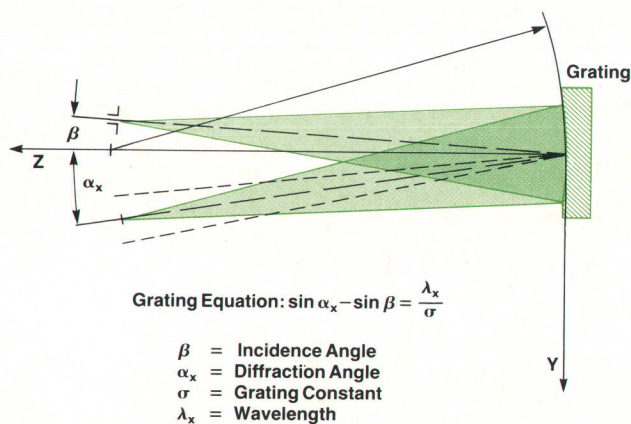
Fig. 6. Selective detection of active compounds in a plant extract by selecting wavelengths.

of a complex mixture (universal detection). On the other hand, when using an individual narrowband signal, certain compounds can be suppressed so that others can be detected with high selectivity. Fig. 6 demonstrates this feature in the analysis of a plant extract in which the active species, flavonoids, cardenolids, and phenolic carbonic acids, have been detected selectively.

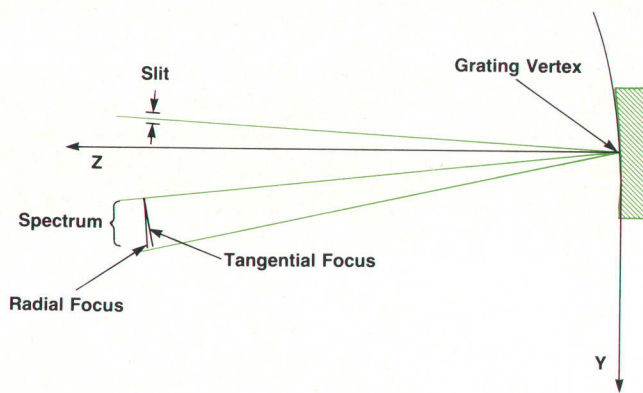
The features illustrated here and a variety of others are expected to open broad application areas for the HP 1040A/79880A Detection System, ranging from the analysis of pharmaceutical formulations, general chemical products, and environmental pollutants to clinical and biomedical methodology, thus contributing to such exciting new developments as, for example, genetic engineering.

Optical and Mechanical Design

The 1040A is a high-speed on-line spectrophotometric detection system dedicated for low-dispersion chromatography. A simple optical configuration with a minimum of components was one of the main design goals to ensure high reliability and low cost of ownership. Another design goal was a reasonable tradeoff between spectral resolution and light throughput to achieve high signal-to-noise performance for high detectability. The objectives of the mechanical design were to eliminate optical adjustments



(a)



(b)

Fig. 7. (a) Basic geometry of the holographic grating. (b) Tangential and radial focal lines are the lines in space where the diffracted image of the entrance slit is best in focus.

by the customer and to provide easy exchangeability of parts (cell, lamp) and extensive diagnostics to make the instrument user-friendly. For low production costs, optical bonding and high-precision NC machining are implemented in the mechanical design.

Illumination System

The flow cell volume of $4.5 \mu\text{l}$ and the path length of 6 mm are predetermined by chromatographic requirements. A conical longitudinal cross section was chosen to give the lowest possible optical dead volume, that is, to give the best possible cell shape for light to travel through (best fit to the optical rays). The diameter of the entry window of the flow cell is limited by the ultrasonic drilling process to a minimum of 0.6 mm. Given this number and the optical geometry, the diameter of the rear cell window can be calculated as 1.3 mm.

From the cone angle of the cell, the maximum allowable aperture of the illumination system can be determined. The other determining parameter of the illumination system is the scaling factor for the image of the light source. This factor is not only limited by the diameter of the entry cell window, but also depends on the dimensions of the diodes of the diode array and on the dimensions of the spectrometer entrance slit.

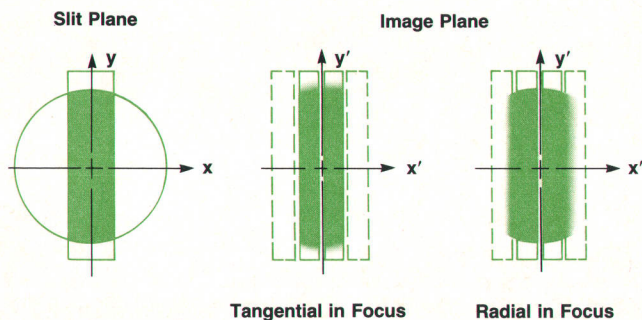


Fig. 8. Intensity distributions of the slit image in the plane of the diode array for a particular wavelength, illustrating tangential and radial focus.

The diode array consists of 211 individual diodes with a center-to-center spacing of $61 \mu\text{m}$. Each diode is 0.5 mm high. Only 205 diodes are used for measuring the wavelength range from 190 to 600 nm. Two additional diodes on each side of the 205 are used for wavelength calibration. As a tradeoff between spectral resolution and high light throughput, the spectrometer entrance slit is made twice as wide as a single photodiode.

An optimum fit of the illumination system to the flow cell geometry means matching the aperture (solid angle matching) and the imaging factor in such a way that the light source image just covers the spectrometer entrance slit (field matching). In this way, reflections at the cell

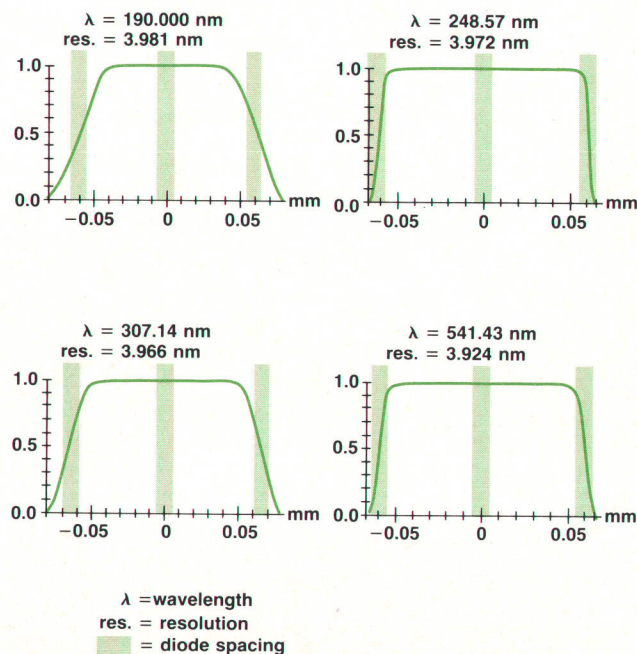


Fig. 9. Intensity distributions of the slit image for pairs of diodes at different points in the diode array, corresponding to different wavelengths.

walls (refractive index sensitivity) are eliminated and maximum light throughput is guaranteed. Both of these demands can be perfectly fulfilled by the use of two imaging elements. Aperture and field stops can be changed independently. Such an illumination system is very flexible and is easily adapted to different cell geometries. However, since the principal goal in the design of the 1040A optical system dictated a minimum of optical components and a nonmodular cell concept, an illumination system with only one imaging element was chosen. To ensure a high light flux, computer-aided ray tracing was done for optimum aperture matching. Because of this tradeoff between aperture and field matching, the resulting imaging factor is below its theoretical optimum. The entrance slit is not fully illuminated in the longitudinal direction.

Spectrometer

The concave holographic diffraction grating is the only optical component of the spectrometer, providing both dispersion and imaging. Fig. 7a shows its basic geometry.

Conventionally, the imaging properties of a grating are characterized by the so-called focal lines, the lines in space where the diffracted image of the entrance slit is best in focus. The astigmatism caused by the off-axis configuration is the main imaging error. The focal lines are calculated for two perpendicular planes corresponding to the directions of slit width and slit height. The distance between these focal lines—the astigmatic difference—is a quality

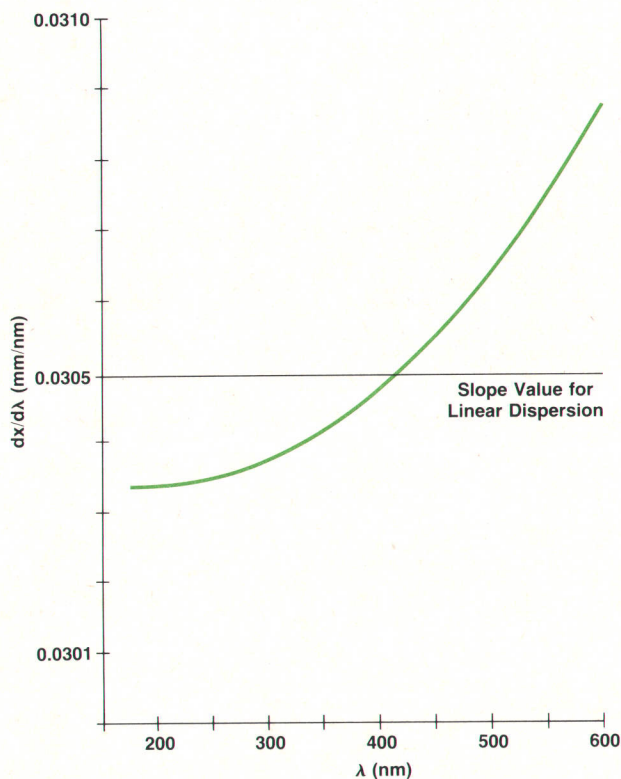


Fig. 10. The dispersion of the holographic grating is non-linear, as shown here. The diode array position corresponds to a best fit linear regression through the tangential focal line. x is the coordinate along the photodiode array.

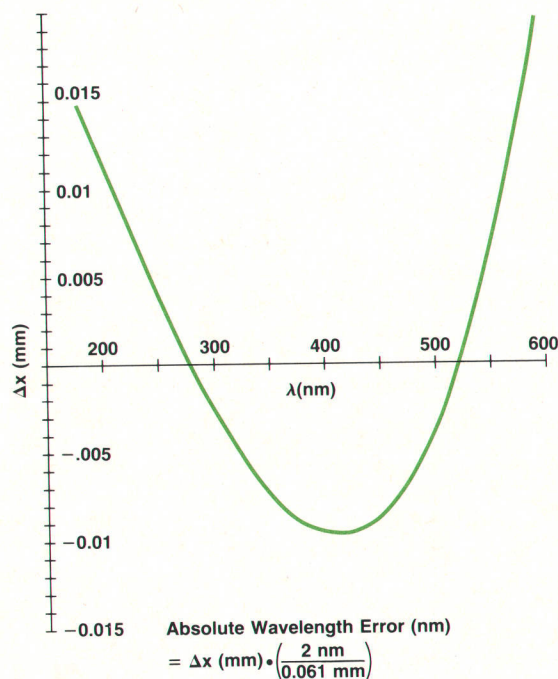


Fig. 11. Absolute wavelength error resulting from nonlinear dispersion is less than 0.5 nm. Specification is ± 1 nm.

criterion of the grating (Fig. 7b).

In the 1040A design, the main problem was to achieve the best possible fit between the focal lines and the linear diode array. Fig. 8 shows the intensity distributions of the slit image for a certain wavelength in the plane of the diode array. For two reasons, the tangential focal line has higher priority than the radial focal line in the optimization process. The first reason is to minimize spectral crosstalk. The second is that even if the image is radially out of focus, all of the light falls on the diode anyway, since the entrance slit is not fully illuminated in the height direction.

Since the focal lines are only qualitative and relative criteria for the imaging properties of the grating, the tangential intensity distribution of the spectral slit image was calculated. Intensity distributions were generated for various wavelengths from the spot images of object points along the entrance slit contours (see Fig. 9). The diode array position corresponds to a best-fit linear regression line through the calculated tangential focal line.

Dispersion

The desirable linear dispersion factor corresponding to the wavelength domain 190 to 600 nm using 205 diodes spaced 61 μm apart is easily calculated as 2 nm per 61 μm . From the basic grating equation (see Fig. 2), it is obvious that the diffraction angle is not a linear function of wavelength. Deviation from linear dispersion as a function of wavelength is shown in Fig. 10. Tracing a linear regression line with a slope of 2 nm/diode through the $x = x(\lambda)$ curve, the wavelength error can be calculated (see Fig. 11). This error is the difference in x between a linear assignment of wavelength to diode number and the real relationship of wavelength to diode number. The maximum wavelength

error of 0.5 nm can be tolerated, since the instrument specification is ± 1 nm.

Using the optimization possibilities of the holographic recording technique, the imaging properties and the dispersion of the grating are fitted to the predetermined geometrical dimensions of the diode array. The grating is produced by replication and has a blazed groove profile optimized for a wavelength of 250 nm in the +1st diffraction order.

Adjustment and Mounting of the Grating

The optical axis of the grating is concentric (± 0.02 mm) with the axis of the substrate, which means that to a good approximation the mechanical axis corresponds to the optical axis. There remain four degrees of freedom in which adjustments have to be done. To provide a noniterative adjustment process, the rotation axes intersect at the apex of the grating. The grating is adjusted with a special tool to the required precision and is bonded into the optical unit. A mercury lamp is used for wavelength adjustment of the grating, and the calculated intensity distributions of the slit images corresponding to the mercury lines on the diode array are used as adjustment aids (Fig. 12). The wavelength calibration is accurate to 0.1 nm. It is sufficient to use only the 313-nm and 546-nm mercury lines for the wavelength calibration. These lines are located near the intersection points of the linear regression line through the tangential focal line and are therefore free of image aberrations (see Fig. 9). Also, the wavelength difference between them is large enough for accurate control.

Mechanical Design

Since the grating is not readjustable, high precision for the positioning of the remaining detector components is required, because the lamp and the flow cell are nonadjustable exchange parts. Also required is exchangeability of the diode array (with built-in grating) by service personnel. Meeting the high precision requirements at low cost was the challenge in the mechanical design.

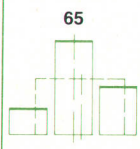
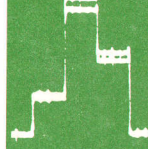
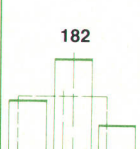
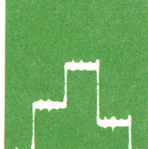
Hg Line nm	Calculated Dispersion		Ideal Case Intensity Distribution	Measured Intensity Distribution
	Center Wavelength	Diode Number		
313	312.58	65		
	314.59	66		
546	546.3	182		

Fig. 12. Calculated intensity distributions are used as aids in adjusting the diode array position.

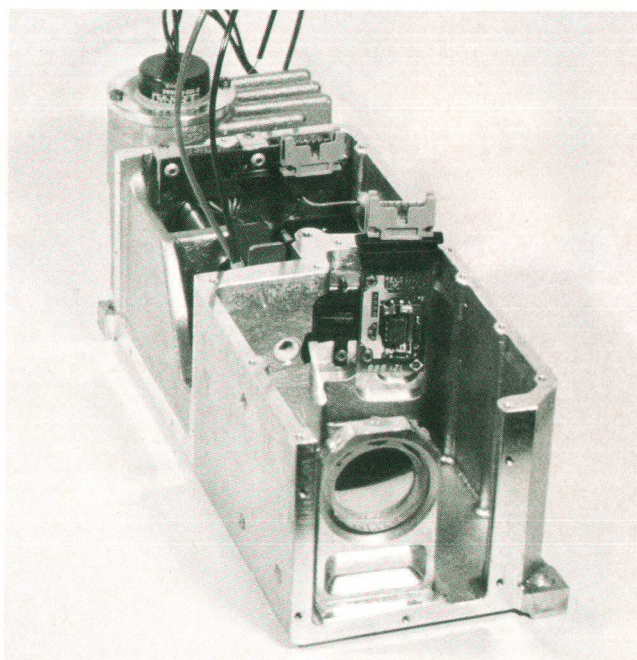


Fig. 13. The optical unit (lighthouse, illumination compartment, spectrometer) is housed in a casting.

The optical unit (lighthouse, illumination compartment, spectrometer) is designed as a casting (Fig. 13). To minimize machining errors, the optical unit is shaped to be machined in a single work mounting. Special constraints imposed by the NC milling machine—for example, the maximum number of tools or the angle resolution of the rotation stage—had to be taken as limiting factors. To determine the dimensional errors caused by the deformation of the optical unit during the machining process, the optical casting was run through a computer analysis. This finite-

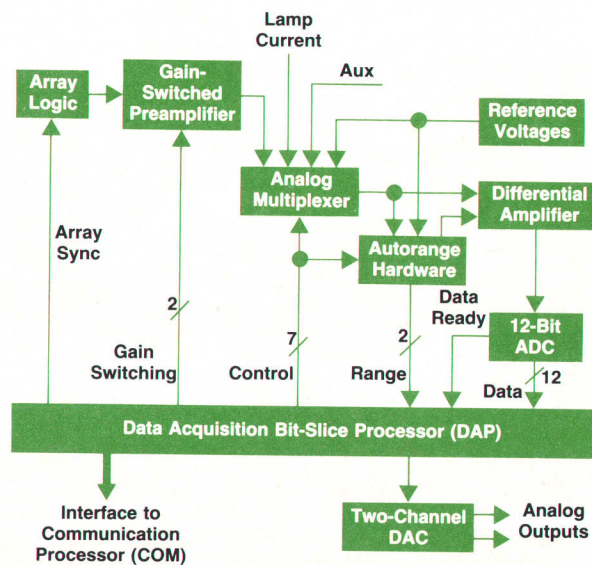


Fig. 14. Simplified block diagram of the HP 1040A front end and data acquisition processor. The design realizes an inexpensive 16-bit analog-to-digital converter (ADC).

element-based analysis also allows optimization of cutting power and cutting speed during the machining process. Finally, a three-dimensional measuring machine is used to check out the machined parts.

Diagnostic Features

A step-motor-driven holmium oxide filter (shutter) lets the user verify the wavelength calibration at any time. In case of a decalibration (for example, after a cell relocation) a wavelength recalibration in 0.5-nm steps in a range of ± 4 nm is possible.

In case of cell leakage, a leak sensor gives the operator a message via the screen. As an additional safeguard, a waste drain in the illumination compartment leads the leak away so that during automatic, unsupervised operation, no further damage is caused.

Each instrument is provided with a test cell. Functionally, this looks like an air-filled cell, so flow-induced effects are eliminated and a quick diagnosis of spectrometer performance can be done.

Front End and Data Acquisition Processor

The 1040A's fast front-end data path digitizes analog data from the diode array and processes it by means of a high-performance bit-slice processor system.

The analog video signal from the diode array logic has to be digitized with a dynamic range of 16 bits. This could be done using a commercial hybrid 16-bit analog-to-digital converter (ADC), but this would be very expensive. Fig. 14 shows the approach taken in the 1040A. A gain-controlled preamplifier is used to split the dynamic analog range into four sections. This gives the two most significant bits. The amplifier gain is processor-controlled and can be set differently for each diode signal. The 211-value gain pattern used during measurements is acquired during a special calibration cycle.

Following the amplifier is a 14-bit ADC consisting of an analog multiplexer, a monolithic 12-bit ADC, and some discrete autoranging hardware. The analog multiplexer provides for the acquisition of several analog signals including ADC reference voltages and lamp current, which are used for calibration and lamp control.

A potential disadvantage of this ADC design is its nonlinear transfer characteristic, which is shown in Fig. 15. There is an offset for an input voltage of zero, and there are steps at the range boundaries. This nonlinearity is corrected by the fast bit-slice data acquisition processor (DAP), which calculates correction values for each range and corrects the raw values for ADC nonlinearity and offset and

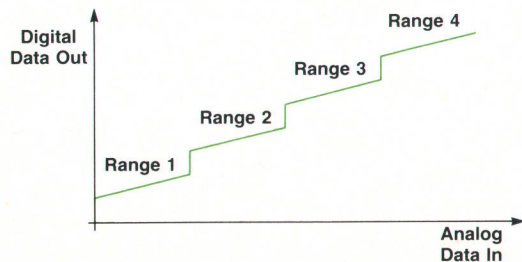


Fig. 15. This nonlinear transfer characteristic of the front-end ADC is corrected by the data acquisition processor (DAP).

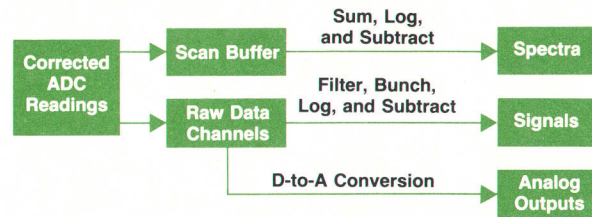


Fig. 16. Data flow in the DAP.

for the dark currents of the photodiodes.

The bit-slice DAP is part of the diode array detector (DAD) multiprocessor system (see article, page 8). It works as a fast data acquisition device, reading data at a rate of 22,500 words per second. This means that all of the diodes of the photodiode array, along with self-calibration data, are sampled 100 times per second. This rate is too high to be processed by a CPU like a Z80A or to be transferred to a mass storage device. The bit-slice processor preprocesses spectrum and signal data so that it can be handled by the DAD communication processor (COM). During data acquisition, the DAP performs more than 60,000 double-word adds or subtracts per second and computes more than 10,000 logarithms per second, doing three 16-bit multiplications for each logarithm.

DAP Functions

One of the DAP's functions is control of the front-end hardware. Every 10 ms, it starts a new diode array sample cycle. Every 44 μ s, it sets the gain of the video preamplifiers to the correct value for the next diode of the diode array. Its third control task is to set the ADC mode depending on the desired conversion of either the array video signal or special input signals like lamp current, references, or preamplifier offset voltages. The DAP also has to support two digital-to-analog converters (DACs), writing output data to the converter registers at a fixed rate of 100 words per second.

The DAP does self-calibration to correct ADC data for nonlinearity and preamplifier offsets. ADC calibration is done continuously, using some extra time slots at the end of every array cycle. During these slots, preamplifier offset measurements are done to obtain offset correction values for each of the four gain settings. This continuous recalibration is done to shorten warmup time and to compensate for drift over time and temperature.

In other time slots at the end of each array cycle, the DAP measures two auxiliary signals. One of these is lamp current. This measurement is used during lamp ignition and to check the lamp status during detector operation.

Data read by the DAP from the A-to-D converter at a rate of 22,500 words per second consists of raw values, which have to be corrected for nonlinearity, preamplifier offsets, and dark values. For each array cycle, the DAP calculates 211 corrected values representing the intensity distribution over the optical wavelength range. These data words are then processed point by point and put either into the scan buffer or into one or more of the eight raw data channels, depending on the desired wavelength ranges of the eight channels (see Fig. 16).

Speed Requirements for Data Acquisition in Photodiode Array HPLC Detectors

A diode array detector acquires absorbance data as a function of wavelength and time. The optical unit directs radiation from a deuterium lamp through a flow cell and then spectrally disperses the transmitted radiation onto a linear array of more than 200 photodiodes, monitoring wavelengths in the range 190 to 600 nm. When transmitted radiation falls on a photodiode, a photocurrent is generated. Each diode is connected in parallel with a capacitor, which is charged to a certain voltage (e.g., -5V). The photocurrent partially discharges the capacitor; this effect provides the basis for the measurement of absorbance. External circuits measure the extent of the discharge when the capacitor is being recharged. The resulting electronic signal is then processed by an analog-to-digital converter and a computer system to give absorbance data.

These events are continuous. The readout is controlled by a shift register and a series of transistor switches that sequentially connect each photodiode to a common line. The time between two readout operations (readout cycle) is characteristic for a diode array detector. This readout cycle determines the spectrum scanning speed or scanning rate.

Speed versus Detection Limit

To demonstrate the impact of data acquisition speed, let's take a closer look at what happens in a photodiode/capacitor pair. If no radiation strikes the photodiode, no discharge of the capacitor occurs. The more intense the incident radiation, the faster the capacitor discharges. As the charge approaches zero, non-

linearities arise in the measurement of the transmitted radiation. When the capacitor is at zero volts, it will not respond to photocurrent until recharged during the next cycle.

Fast data acquisition allows us to use high-intensity radiation without saturating the photodiode array. The signal is proportional to the light intensity. Noise, however, is proportional to the square root of the light intensity. More intense incident radiation therefore leads to a higher signal-to-noise ratio. Thus, when all other parameters are the same, the limit of detection is lower and detectability is better with higher-speed data acquisition.

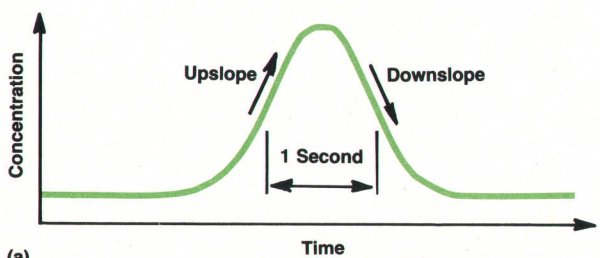
Speed versus Spectrum Quality

A major advantage of a diode array detector is the ability to monitor eluants from short, highly efficient HPLC columns. Components elute from such columns in a very short time, as little as a few seconds. During elution, the concentration of a compound in the mobile phase changes quickly from zero to a maximum and back to zero. The amplitude of an absorbance spectrum will change proportionally with the concentration. The shape of the spectrum, however, ought to remain constant (if only one compound is eluting at that time).

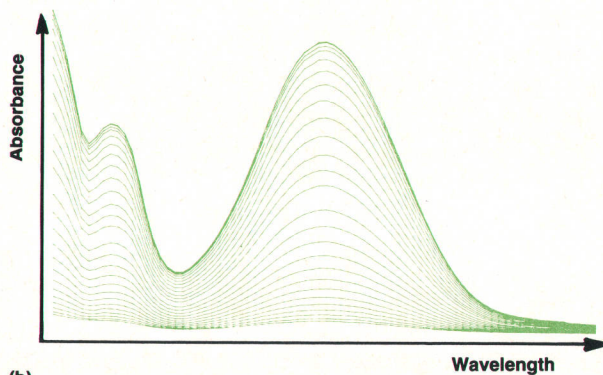
Assume we have a model peak, having a width of one second at 50% amplitude (Fig. 1). We take absorbance spectra during the upslope of the peak at intervals of 0.04 second. Assume that each of these spectra is acquired in an infinitely short period of time, so that it shows the true absorbance at a certain instant. The same series of spectra will occur in reversed order on the downslope, because the model peak is perfectly symmetrical.

If the spectrophotometer takes a full spectral scan in a relatively fast 0.3 second, the scan speed is too slow for this peak (see Fig. 2). The spectrum is deformed because of changes in concentration between readings taken at the shortest wavelength and those taken at the longest wavelength. Instead of the same spectra on the upslope and the downslope, the result is two completely different spectra of the same compound taken at different times during its elution.

Fig. 3 shows the result of high-speed data acquisition, with a full spectral scan taken in 0.01 second. The result is accurate spectra, identical on the upslope and the downslope.



(a)



(b)

Fig. 1. (a) Model chromatographic peak. (b) Instantaneous spectra taken on the upslope of a model chromatographic peak at 0.04-second intervals.

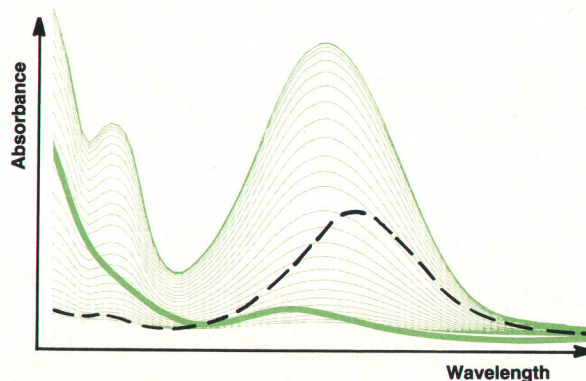


Fig. 2. Spectra (0.3-second full-scan time) taken on the upslope and downslope of a model chromatographic peak.

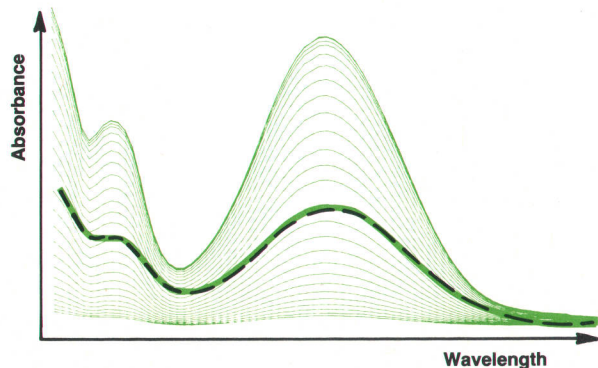


Fig. 3. Spectra (0.01-second full-scan time) taken on the upslope and downslope of a model chromatographic peak.

On the other hand, the longer the observation of the absorbance spectrum (exposure time), the lower the spectral noise, and vice versa. Thus the faster measurement will have a lower signal-to-noise ratio. However, noise can be decreased by averaging. If we take an average of a number of items, random noise will decrease by the square root of the number. In the same 0.3 second that it took to get the inaccurate result of Fig. 2, we can take 30 accurate 0.01-second spectra and average them, decreasing the relative noise by about the square root of 30. In other words, high-speed data acquisition combined with averaging yields both valid spectra for fast peaks and an accept-

able signal-to-noise ratio.

Speed versus Computer Power

Although faster acquisition of data from the photodiode array gives better results, the faster we scan the array, the more difficult it becomes for the electronics. As a result of the 0.01-second readout cycle in the HP 1040A HPLC Detection System, the data processing electronics must be able to:

- Take 22,500 readings per second from the analog-to-digital converter (including measurements used for continuous recalibration and fault monitoring)
- Make several correcting calculations for each measurement (e.g., dark current)
- Extract, on-line, up to 8 chromatographic signals with variable bandwidth
- Take an average of a variable number of scans
- Calculate logarithms to convert radiation measurements into absorbance measurements, and provide results on-line.

To perform this list of functions requires the execution of about 4 million arithmetic operations per second. Standard 8-bit or 16-bit microcomputers cannot perform to that requirement. Many 32-bit architectures are not designed for the task. To perform the tasks of high-speed data acquisition, the HP 1040A has a network of microprocessors, including a set of high-speed, bipolar arithmetic units called bit-slice processors, as described in the accompanying article. As a result, it not only gives valid results for fast HPLC peaks, but also has a detection limit competitive with single-wavelength UV/Vis detectors.

Spectral data is acquired only on request. The scans from each array cycle are summed together until the desired acquisition time is over, but they remain separated in the wavelength domain. After a spectrum period is completed, data is logarithmically converted and a background spectrum is subtracted. The result is an absorbance spectrum with 211 values, which is sent to the COM processor.

The raw channel data is filtered using boxcar stages (running average of the last n values) and bunch elements (sum of the last n values with rate reduction by n , i.e., one output data point for each n input data points). There are several boxcar/bunch stages for each channel; the number of stages used determines the electrical bandwidth and the corresponding base sample rate. When an acquisition period is

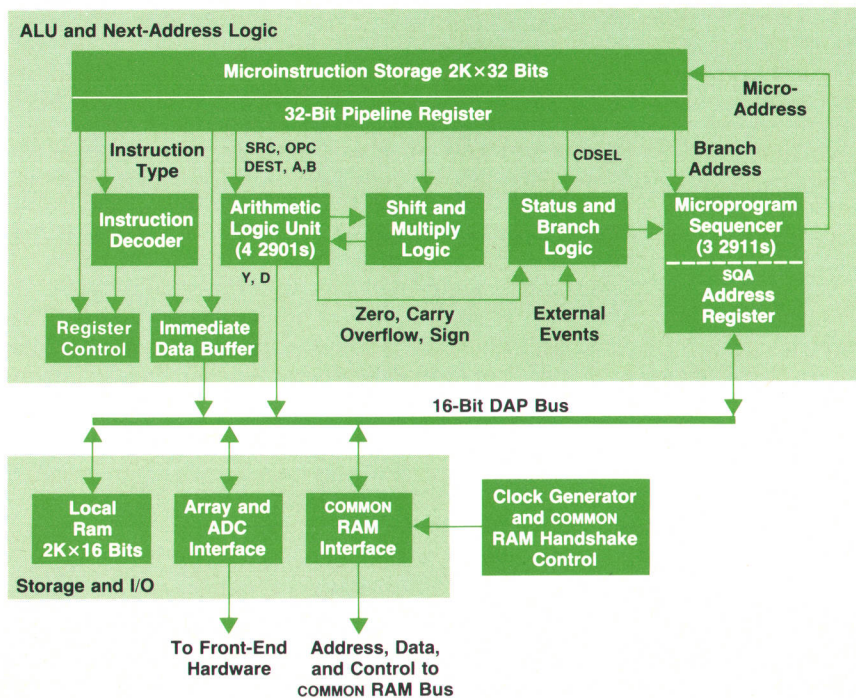


Fig. 17. Block diagram of the bit-slice DAP. This 16-bit processor takes ADC data at 22,500 words per second and computes absorbance and spectral data.

over, eight absorbance signals are calculated and transferred. Absorbance calculation is quite similar to that used for scans.

All calculations are done internally with double (32-bit) precision, but to save buffer space and transfer time, the precision of logarithms for spectra is reduced to 16 bits.

Bit-Slice Hardware

The DAP bit-slice system (Fig. 17) is built of four 2901 ALU (arithmetic logic unit) slices for a 16-bit-word data handling capability. This corresponds to the width of the data words coming from the analog-to-digital converter and is the best tradeoff between the amount of hardware and the required processing time. The instruction word width of 32 bits allows multifunction instructions for increased processing speed. It is possible, for instance, to combine an arithmetic function, a shift/rotate operation, an input/output transfer, and a jump or call function. These multifunction instructions are optimized to the needs of the diode array detector.

The next-address logic, which controls stack operations and conditional or unconditional jumps or calls, uses three 2911 sequencers, enough to address the $2K \times 32$ -bit instruction PROMs. The clock frequency used is 4.5 MHz. With the pipelining of the instruction path, which prevents processor slowdown by PROM access time, the instruction execution time is 220 ns. Accessing the $2K \times 16$ -bit local RAM, or during I/O, one or two 55-ns quarter cycles are added to handle the longer access times of these devices.

There are two interrupt lines. Interrupt events are handled like any status information and must be polled by software. One line is used for communication with the COM processor, and the other synchronizes data input from the ADC and control output to the several hardware control registers of the array front-end electronics.

Bit-Slice Development Tools

For DAP software development, an HP internal software package was used. Running on the HP 3000 Computer System, it consists of a configurable assembler package that

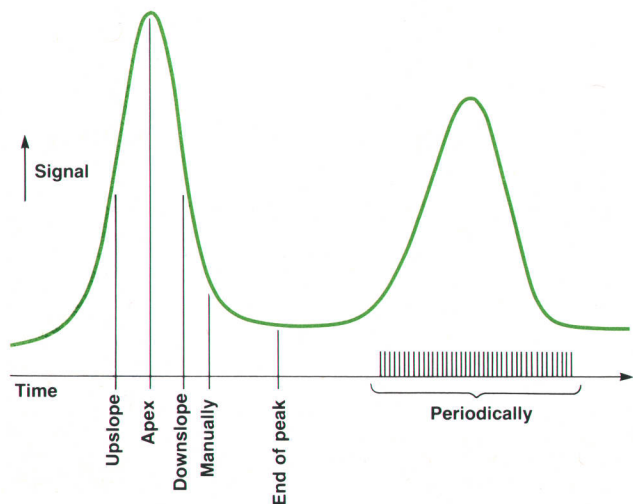


Fig. 18. Spectra can be taken by keystroke request, periodically, or at various points on a peak.

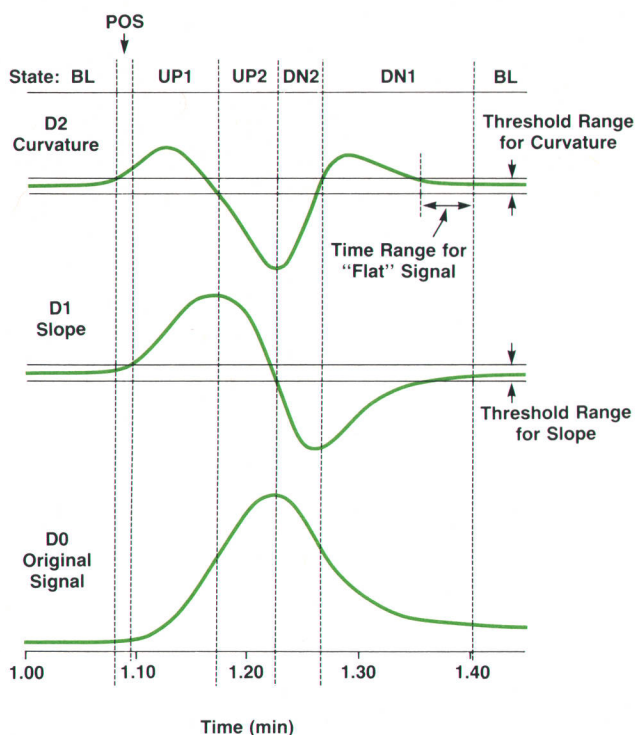


Fig. 19. Slope and curvature signals and thresholds used in detecting peak inflection points.

can be adapted to any hardware configuration. Instruction mnemonics can be defined by the user.

To replace the instruction PROMs during the development phase, a special PROM simulator or writable control store was built. To control the simulator and to download software written on the HP 3000, an HP 9835 Computer and some interface software were used. An HP 1610B Logic State Analyzer was used to check for hardware problems and to debug the software.

Data Processing

Data processing in the diode array detector is implemented on the COM processor, a Z80A. Its main purposes are selection and formatting. The outputs of this step are a raw data file to be stored on disc for off-line evaluation, and/or scaled graphics to be plotted on the HP-85 screen for on-line monitoring.

The inputs for the data processing step, which are delivered by the data acquisition processor (DAP), consist of signals (blocks of eight 4-byte values) and spectra (blocks of 211 2-byte values). The user can define the wavelengths, the time base, the number of signals to be stored on the file, and what spectra will be stored.

Three modes are available for spectrum selection. Spectra can be selected in three ways:

- Manually upon keystroke request
- Periodically at a selectable time interval
- Peak controlled (at the apex, on the slopes, or at the end of a chromatographic peak).

Fig. 18 illustrates the different spectrum selection modes. For normal applications, the peak controlled mode is most

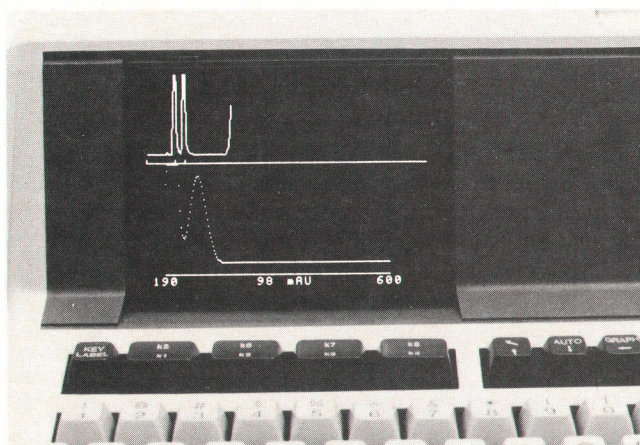


Fig. 20. For on-line monitoring of diode array detector results, the HP-85 screen shows the evolving chromatogram (top trace) and spectra updated at about one-second intervals (bottom trace).

interesting, since it reduces the huge number of available spectra to relevant and manageable information.

Peak Detection

The user selects one of the signals as a pilot signal, which is then fed into a peak detector to determine the points of interest where spectra are to be taken. The peak detector is a piece of software that implements a state machine. Each state represents a particular set of pilot signal characteristics. The transitions between states are the relevant points for spectrum selection.

To determine the characteristics of the pilot signal, the first and second derivatives are calculated, representing the slope and curvature of the signal. To cope with the ever present noise on the signal, the derivative calculations include a digital filtering step.

The peak detector has to discriminate between the baseline and the peak, and within the peak has to find upslopes, downslopes, valleys, shoulders, and the apex. The necessary states are:

- Baseline (BL): curvature zero
- Concave (POS): curvature positive, slope zero
- Convex (NEG): curvature negative, slope zero
- Upslope 1 (UP1): curvature and slope positive
- Upslope 2 (UP2): curvature negative, slope positive
- Downslope 1 (DN1): curvature positive, slope negative
- Downslope 2 (DN2): curvature and slope negative.

To improve noise immunity, there is a threshold range around zero. Therefore, "positive" means "greater than positive threshold," and "negative" means "less than negative threshold" (see Fig. 19).

Spectrum Acquisition

The straightforward method of spectrum acquisition would be to command the DAP to measure a spectrum whenever an interesting state transition occurs in the peak detector (e.g., UP2 to DN2, indicating the apex of the peak). However, this solution is not acceptable because of a double delay. The first is the delay in peak recognition (half of the length of the curvature filter), and the second is half of the

acquisition time of the spectrum. Therefore, spectra are taken periodically and stored by the COM. If then an apex or other interesting point in the signal is detected, the available spectra are searched for the one with an acquisition time closest to the required time. This spectrum is marked for later storing to the output file. Up to six spectra can be stored. This is enough, because the acquisition rates for signals and spectra are about the same, so the time span between the newest spectrum and the oldest just has to equal the delay in peak recognition. The number of immediately stored spectra is constant. When a new spectrum arrives from the DAP, the oldest spectrum is overwritten by the new one. However, if this oldest spectrum is marked, it is first stored to the output file.

Using Stored Data

The output data file consists of a number of records, each containing either a spectrum or some signal data. With each spectrum are stored the acquisition parameters for it (wavelength range, time and duration of acquisition). The signal acquisition parameters (wavelengths, bandwidths, sample and reference path measurement, time base, pilot signal) are stored whenever there is a change in any of them. The file also contains some directory information and some general information about the analysis. Thus the raw data file contains all of the information needed for off-line data processing.

For on-line monitoring, the HP-85's graphics screen is continually updated. In the upper half of the screen is the evolving signal (chromatogram). In the lower half of the screen is a spectrum (see Fig. 20). The spectrum is valid for only one instant of time and is redrawn as each new spectrum is acquired. Since spectra can normally be acquired in less than one second, the changing display lets the user visualize the movement of the eluant through the flow cell.

Acknowledgments

Thanks to Alfred Maute, 1040A project manager, for the initial instrument concept, and for his guidance and valuable assistance. The efficient collaboration between the software and the hardware teams during the entire project was essential for the success of the 1040A. The flow cell assembly, the lamp assembly, and the corresponding production tools were designed by Klaus Baier. Special thanks to Roland Ebner and the people at the metal shop in Boeblingen for their support in the machining of the optical unit.

Authors

April 1984

3

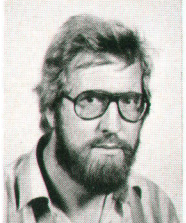
Robert J. Jonker



Robert Jonker received his undergraduate degree in analytical chemistry in 1973 and his PhD in high-pressure gas chromatography in 1982. Before coming to HP in 1982, he worked in spectroscopy, liquid and gas chromatography, and instrument development.

He has published or presented a number of scientific papers on chromatography. Formerly responsible for final test of the HP 1090 LC, he's now a project manager. He was born in Amsterdam and now lives in Waldbronn.

Gerard P. Rozing

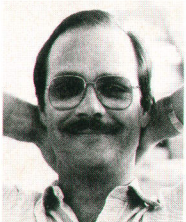


Gerard Rozing was born in Heemskerk, The Netherlands. He did his undergraduate work at the Municipal University of Amsterdam, and in 1976 received his PhD degree there in organic chemistry. After postdoctoral studies in organic chemistry at the

State University of Ghent, Belgium and in analytical chemistry at Amsterdam, he joined HP in 1979. He has been responsible for R&D on LC columns and packing materials, and is now section leader for chemistry and detection projects. Gerard enjoys tennis, jogging, soccer, and working on his new house in Stupferich, near Waldbronn, Federal Republic of Germany. He's married and has two daughters.

7

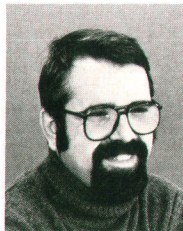
Bernd Glatz



Bernd Glatz is LC applications manager with HP's Waldbronn Division. He has a PhD degree in chemistry. With HP since 1978, he was formerly HP 1090 product manager. He is the author of several professional papers and has a background in organic chemistry.

Bernd is married, was born and still lives in Stuttgart, and enjoys water sports, tennis, skiing, and chess.

Rainer Schuster

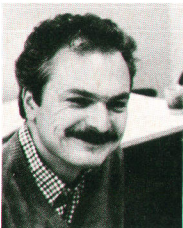


Moses Schuster is an applications chemist with HP's Waldbronn Division. He joined HP in 1976. He holds a PhD degree, is an expert on crystallography and high-performance liquid chromatography, and has authored or coauthored more than 30 papers. Born

in Karlsruhe, Federal Republic of Germany, he is married and lives in Karlsruhe. Among his interests are music, history, philosophy, and gardening.

8

Roland Martin



Roland Martin received his Grad. Ing. at the Nachrichtentechnik Fachhochschule Esslingen and joined HP in 1969 as a production engineer in Böblingen. An R&D engineer at the nearby Waldbronn Division since 1975, he's now a section manager there.

Roland was born in Stuttgart, lives in Waldbronn, and walks to work at HP. He and two friends own and fly a high-performance glider. Roland also plays volleyball on the HP team.

Juergen Ziegler



Juergen Ziegler joined HP in 1979 with experience in software development for business computers, and has contributed to the development of operating systems and software for the HP 1040A and the HP 1090. A member of the IEEE, he received his Diplom Informatik at Karlsruhe in 1977. Born in Mannheim, Juergen lives in Karlsruhe. He's married, has three children, plays volleyball on the HP team, and likes to ski.

Herbert Wiederoder

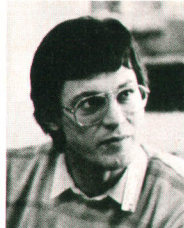


A native of Stuttgart, Herbert Wiederoder received his Dipl. Ing. at the Technical University of Berlin and his Grad. Ing. at the Fachhochschule Ulm. With HP since 1977, he's contributed to the software design of the 1084B LC and the hardware and software design of the 1090 LC controller. Now an R&D project leader, he's a member of Gesellschaft für Informatiker. Herbert lives in Spielberg, near Waldbronn.

He's married, has a son and a daughter, and enjoys tennis and skiing.

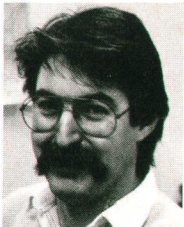
13

Wolfgang Geiger



Wolfgang Geiger holds the equivalent of a BSME degree from the Fachhochschule Esslingen/N. With HP since 1975, he was project leader for the mechanical design of the 79835A SDS, and is now a production engineer. Born in Tübingen, Federal Republic of Germany, he lives in Ettlingen. He's married, has a daughter and a son, and enjoys tennis, soccer, and photography.

Heinrich Völlmer



A native of Karlsruhe, Federal Republic of Germany, Heinrich Völlmer graduated from the Fachhochschule Karlsruhe in 1978 and joined HP's Waldbronn Division the same year. He did electrical engineering for several solvent delivery system

projects, and served as project leader for the electronic design of the 79835A SDS. He's now SDS group leader. A member of VDI, Heinrich is married, has a son, and lives in Ettlingen. Besides playing trombone in several bands, he enjoys photography and traveling.

21

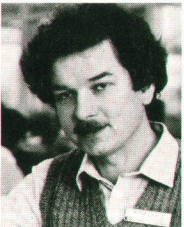
Hans-Georg Härtl



Hans-Georg Härtl has been with HP since 1979 and has contributed to the design of the autosampler and the SDS for the HP 1090 LC. His work has resulted in a patent and a patent application on different damping systems for LCs. Born in Mannheim, Hans-Georg

received his Dipl. Ing. in precision engineering from the Fachhochschule Furtwangen. He has two years of military service to his credit. He lives in Karlsruhe, and his interests include motorcycles, scuba diving, and his seawater aquarium.

Wolfgang Kretz

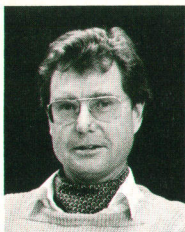


Wolfgang Kretz received his Ing. Grad. in mechanical engineering from the Fachhochschule Konstanz in 1972 and his Diplom Ingenieur in precision mechanics from the University of Stuttgart in 1978. After joining HP in 1978, he designed improvements to

the 79841A Injector and served as project leader for the 79846A Autoinjector. He's now a production engineer for the 1090 LC. Wolfgang was born in Buchheim, Federal Republic of Germany, and now lives in Waldbronn. He's married, has two daughters, and enjoys photography, reading, and family outings.

24

Helge Schrenker



Helge Schrenker graduated in applied physics (Dipl. Ing.) in Hamburg in 1967. He came to Hewlett-Packard with the acquisition of Hupe & Busch, then a well known German manufacturer of chromatography equipment. Until 1978 he was LC product marketing manager of the newly formed Waldbronn Analytical Division. He then transferred to R&D where he wrote the product definition and ERS for the 1090 Liquid Chromatograph and also contributed to its development as an R&D group leader. Since 1982, he has served as the Division's product assurance manager. He's married and enjoys hiking, traveling, and photography.

26

Axel Wiese



He has authored or coauthored a number of papers in the field of microwave instrumentation. Axel lives in Karlsruhe and is interested in traveling, archaeology, and collecting old books.

Bernhard Dehmer



Bernhard Dehmer has been a mechanical engineer with HP's Waldbronn Division for two years. He holds a Dipl. Ing. in precision mechanics. Born in Karlsruhe, he is married, has a child, and lives in Rastatt.

Thomas Dörr



Thomas Dörr first joined HP in 1981 as a trainee in R&D. He received his degree in electromechanics and automation at Karlsruhe in 1982 and is now an electronic engineer in the detector group of the Waldbronn Division. Thomas lives in Karlsruhe, 80 km from Heilbronn, where he was born. He is married, and his interests include playing go, photography, raising turtles, hang gliding, playing table tennis, and motor biking.

Günter Höschele



A designer of microprocessor hardware and software at HP's Waldbronn Division, Günter Höschele contributed to the design of the 1040A Detection System's data acquisition processor and the data processing circuits for the 79881A Filterphotometric Detector. Born in Stuttgart, he received his Diplom Ingenieur in electronics from the University of Stuttgart in 1977 and joined HP in 1979. Günter enjoys music and reading. He lives in Langensteinbach, near Karlsruhe.

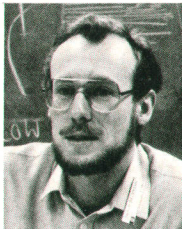
31

Joachim Leyrer



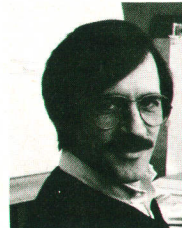
Joachim Leyrer came to HP in 1980 as a marketing specialist in UV/Vis spectrophotometry and high-performance liquid chromatography. He's now a product marketing engineer with HP's Waldbronn Division. He holds a degree in chemical engineering.

Joachim Dieckmann



Joachim Dieckmann received his Diplom Informatiker in 1978 from the Technische Hochschule Darmstadt. After three years in the development of Pascal compilers, he joined HP in 1981. He helped develop the firmware for the 1040A Detection System and is now a project leader. Joachim is a member of the ACM and a native of Berlin. His interests include sailing, surfing, bicycle touring, and hiking.

Detlev Hadbawnik



Detlev Hadbawnik received his Dipl. Ing. in precision mechanics and optics in 1969 and his Dr. Ing. in modern optics in 1975, both from the University of Stuttgart. Before coming to HP, he did research in modern optics, holographic endoscopy, fiber optics, optical image processing, and laser applications in medicine. His work has resulted in four papers and a patent in the field of holographic endoscopy. A member of the German Society of Applied Optics, he joined HP in 1979 and contributed to the optical and mechanical design of the 1040A Detection System. Detlev was born in Hermannstadt, Romania. He is married, has two children, enjoys tennis, skiing, and photography, and lives in Waldbronn.

Günter E. Nill



Günter Nill received his Diplom Chemiker in 1976 and his Dr. Rer. Nat. in 1979 from the University of Stuttgart. With HP since 1979, he's served as an LC sales support engineer and as product manager for the 1080 LC and the 1040A Detection System. He's now product manager for the 1090 LC for North America. Günter is a member of the Gesellschaft Deutscher Chemiker, a native of Groetzingen, Federal Republic of Germany, and a resident of Nuertingen. His hobbies include skiing, building radio-controlled gliders and cars, and woodworking.

44

Alfred Maute



With HP's Waldbronn Division since 1972, Alfred Maute is now engineering manager, having previously served as section manager, group leader, and R&D engineer. A graduate of the University of Stuttgart, he received both his Dipl. Phys. and his PhD in physics there, the latter in 1972. He's also done postdoctoral work in photochemistry and has published five papers on photochemical topics. A member of Gesellschaft Deutscher Chemiker, his work has resulted in a patent on variable-wavelength LC detection instrumentation. Alfred is married, has two daughters, lives in Waldbronn, and enjoys tennis and skiing.

New Technologies in the HP 1090 Liquid Chromatograph

by Alfred Maute

Engineering Manager
Waldbronn Division

In making a new generation of any technical product, new technology and processes will usually be applied wherever feasible. In fact, new and/or improved technology may well be the main or the only reason to replace an existing product.

On the other hand, if you decide to expand your instrument's or system's range of capabilities significantly beyond traditional or present limits, technologies and processes may not be so easily identified, tested, applied, and established.

A few years ago, we decided to extend the flow range of a liquid chromatograph down to a few microliters of solvent per minute (which compares to the amount of liquid flowing through the capillaries of a small plant). Doing this within an analytical technique, whose quantitation requirements for resolution and reproducibility are only a few tenths of a percent, you must control the motion of liquid volumes of a few nanoliters (a nanoliter is $0.1 \times 0.1 \times 0.1$ mm) under pressure ranges of 200-500 bar (3000-7000 psi). To do this, all flow-related devices in the system, which have to be made of a few chemically inert materials like stainless steel, quartz, ceramic, gold, or Teflon™, have to be miniaturized in volume and geometry. Miniaturization, of course, is a well established trend. Vast experience has been built up in controlling microdimensions of semiconducting materials, plastics, metals, and organics, and we were glad to make use of it.

But a few aspects were different. We had to look into not just miniature passive parts and devices, but rather into miniature machinery, like reciprocating liquid pumps, valves, and liquid sampler devices. Moving mechanical parts are subject to wear when several hundred thousand or even millions of cycles are anticipated over a lifetime. So technologies like precision machining, surface coating, polish, and finish, which are fairly highly developed and traditional and beginning to become historical, had to be rediscovered and reactivated for use in the HP 1090.

For example, the drilling of tiny holes with diameters like 200 μm , or cutting miniature threads into bulk stainless steel, used to be part of the daily work (or artwork) of the mechanical-wristwatch makers of the Black Forest and Switzerland. Ruby, sapphire and quartz were common materials for them to cut, shape, perforate, and polish to optical quality. We were able to adapt the machinery, tools, and test equipment from this traditional industry, and to develop and establish interest and human

skills for this kind of work in the HP Waldbronn Division.

Using ceramic doesn't seem exciting or difficult, as long as you don't want to apply it to a moving, nonlubricated sealing surface in a liquid microvalve expected to operate over a couple of years at very low leakages. During the development of this device we learned how far from trivial this problem is. There are very few experts in the world to consult with. The solution requires control of critical bulk material properties, ultrasonic machining, precise surface parameters, and a sophisticated actuator mechanism. The resulting valve represents a real advance in this key element of a liquid chromatograph.

When 100- μm I.D. steel capillaries need to be connected to LC devices like columns or detector cells, the standard threaded fitting must be adapted to the 0.5-mm O.D. of the capillary. This involves the process of stainless-steel welding of a concentric seam at a distance of 200 μm from a 100- μm I.D. open bore. The technology of choice here is laser welding, but at tremendous cost of equipment and even cost per seam, reason enough for our metal shop people to invent a semiautomated microplasma welding device, generating the circular seam in a few seconds over the capillary's cross section, and keeping the bore open by shaping the plasma through a tiny gas jet.

Having discoursed at length about these micro and precision mechanics and processes, I must also point out that two thirds of the project team consisted of electrical engineers, computer scientists, and chemists. They contributed technologies such as bit-slice processor technology, which we adapted from the HP 2680A Laser Printer for data acquisition and processing in the photodiode array detector. Fast, high-resolution servo motor control technology came from HP Laboratories into our liquid metering pump drives to control the motion of the sapphire plungers down to 1- μm resolution. Key strategies in the software and hardware architecture of the multiprocessor system in terms of distribution, interfacing, and communications pay off for our customers in the flexibility, modularity, and upgradability of the whole family of liquid chromatographs. One aspect of this architecture is to use standard communication hardware and protocols like the HP-IB or RS-232-C to provide any system extensions. This is crucial for computerization and networking in the analytical laboratory of today and tomorrow.

Address Correction Requested
Hewlett-Packard Company, 3000 Hanover
Street, Palo Alto, California 94304

Bulk Rate
U.S. Postage
Paid
Hewlett-Packard
Company

HEWLETT-PACKARD JOURNAL

APRIL 1984 Volume 35 • Number 4

Technical Information from the Laboratories of
Hewlett-Packard Company

Hewlett-Packard Company, 3000 Hanover Street
Palo Alto, California 94304 U.S.A.

Hewlett-Packard Central Mailing Department
Van Heuven Goedhartlaan 121

1181 KK Amstelveen, The Netherlands

Yokogawa-Hewlett-Packard Ltd., Suginami-Ku Tokyo 168 Japan

Hewlett-Packard (Canada) Ltd.

6877 Goreway Drive, Mississauga, Ontario L4V 1M8 Canada

CHANGE OF ADDRESS: To change your address or delete your name from our mailing list please send us your old address label. Send changes to Hewlett-Packard Journal, 3000 Hanover Street, Palo Alto, California 94304 U.S.A. Allow 60 days.